

# Rosemount 144 PC-Programmable Temperature Transmitter

- *Provides an installation-ready solution for temperature monitoring applications using Complete Point Solutions (CPS)*
- *Increases measurement accuracy and reliability over sensors wired direct*
- *Accepts 2- and 3-wire Pt 100 and Ni 100 RTD sensor inputs*
- *Reduces overall installed costs compared to wiring sensors direct*
- *Is configurable using the Rosemount 144C Configuration Interface and a standard PC*



## Content

The Rosemount 144 .....	page 2
Specifications .....	page 3
Hazardous Locations Certifications .....	page 4
Dimensional Drawings .....	page 5
Ordering Information .....	page 7

## Model 144H

# The Rosemount 144 PC-Programmable Temperature Transmitter

The Rosemount 144 is a low cost temperature transmitter used for RTD-only sensor measurement in monitoring applications. Compared to wiring direct, the Rosemount 144 will save money in cabling and installation costs while delivering improved measurement accuracy and reliability.

### INSTALLATION READY SOLUTIONS

The Rosemount 144 is part of the Complete Point Solutions (CPS) program. CPS guarantees that the transmitter, sensor, extension, and thermowell will be shipped from the factory as an installation-ready assembly.

### INCREASED PERFORMANCE

The Rosemount 144 offers better measurement accuracy and improved reliability over wiring a temperature sensor directly back to the DCS. Also, the 4-20 mA signal from a transmitter is not as sensitive to noise as a long run of sensor wire.

### FLEXIBILITY

The Rosemount 144 is compatible with 2- and 3-wire nickel and platinum RTDs, as well as ohm inputs.

### LOW INSTALLED COST

The Rosemount 144 reduces overall installation costs when compared to wiring sensors direct. In addition, the 144 can eliminate the use of expensive extension wires and multiplexers.

### PROGRAMMABLE

The Rosemount 144C Configuration Interface consists of a programmer, cables, and configuration software. The configuration software, when used in conjunction with the interface, provides the tools necessary to select the sensor type, sensor range, and sensor error action in addition to many other options.

## Rosemount Temperature Solutions

### Rosemount 3244MV Temperature Transmitter

Field mount style available with Profibus-PA protocol.

### Rosemount 644 Smart Temperature Transmitter

Head or rail mount styles available with HART or FOUNDATION fieldbus protocol.

### Rosemount 848T Eight Input Temperature Transmitter

Eight input transmitter available with FOUNDATION fieldbus protocol.

### Rosemount 3420 Fieldbus Interface Module

Provides an interface between FOUNDATION fieldbus instruments and systems without fieldbus capability using standard interface protocols.

### Rosemount 248 Temperature Transmitter

Head mount style (DIN B) available with HART protocol and complete temperature assembly.

### Rosemount 244ER Temperature Transmitter

Rail mount style that is PC-programmable.

### Rosemount sensors, thermowells, and extensions

Rosemount has a broad offering of RTD and thermocouples that are designed to meet plant requirements.

# Specifications

## FUNCTIONAL

### Supply Voltage DC

Standard: 8.0 to 35 V  
Intrinsic Safety: 8.0 to 28 V

### Minimum Voltage Across Terminals

8 V dc

### Turn-on Time

Performance within specification less than 5.0 minutes after power is applied to the transmitter

### Isolation

No input to output isolation

### Communication Interface

Rosemount 144C Configuration Interface software and hardware

### Calibration Temperature

20 °C to 28 °C (68 °F to 82.4 °F). Temperature Coefficient (spans greater than 100 °C). Less than ±0.01% of configured span / °C.

### Temperature Coefficient (spans less than 100°C)

±0.01 °C / °C<sub>ambient</sub>

### Ambient Temperature Limits

Operating: -40 to 85 °C (-40 °F to 185 °F)

### Humidity Limits

0 to 95% relative humidity, non-condensing

### Maximum Offset

50% of selected maximum value recommended

### NOTE

In order to meet specification, the minimum temperature value of span (°C) must be less than or equal to 50% of the maximum temperature in the span. For example, a span of 50 to 100 °C is recommended but a span of 75 to 100 °C is not recommended.

### Maximum Cable Resistance Per Wire

10 Ω

### Sensor Current

0.2 < I < 0.4 mA

### Linear Resistance Input

Measurement Range:	0 to 10 KΩ
Minimum Measurement Span:	30 Ω

### Output

Signal Range:	4–20 mA
Update	13 milliseconds
Load Resistance (Ω):	Ω ≤ (V supply - 8 V)/0.023 A
Load Stability	< ±0.01% of configured span 100Ω

### Alarm Levels

Programmable:	3.5 to 4 mA downscale 20 to 23 mA upscale
NAMUR NE43 Upscale:	21 ≤ I ≤ 23 mA
NAMUR NE43 Downscale:	I ≤ 3.6 mA

### Input

	Pt 100	Ni 100	Linear Resistance
Min. Value	-200 °C (-328 °F)	-60 °C (-70 °F)	0 kΩ
Max. Value	850 °C (1562 °F)	250 °C (482 °F)	10 kΩ
Min. Span <sup>(1)</sup>	25 °C (45 °F)	25 °C (45 °F)	30 Ω

(1) Recommended minimum span

Sensor Options	Recommended Minimum Span <sup>(1)</sup>	
2-, 3-wire RTDs	°C	°F
Pt 100 (a = 0.00385)	25	45
Ni 100	25	45
Linear Resistance	30 Ω	

(1) No minimum or maximum span restrictions within the input ranges. Recommended minimum span will hold noise within accuracy specification with damping at zero seconds.

## PERFORMANCE

### Accuracy

Sensor Options	Accuracy
2-, 3-wire RTDs	
Pt 100 (a = 0.00385)	0.1% of span or 0.3 °C, whichever is greater
Ni 100	0.1% of span or 0.3 °C, whichever is greater
Linear Resistance	0.1% of span or 0.2 Ω, whichever is greater

### Programmable Response Time (Damping)

0.33 to 60 seconds

### Linearity Error

Less than 0.1% of configured span

### Effect of Supply Voltage Change

Less than/equal to 0.005% of configured span V dc

### EMC-Immunity Influence

Less than ±0.5% of configured span

### Improved EMC Immunity

NAMUR NE21 A – criteria for burst < ±1% of configured span

### Vibration

IEC 68–2–6 Test FC

### Lloyd's Specifications No. 1

4 g / (2 to 100 Hz)

### Effect of Sensor Cable Resistance (3-wire)

Less than 0.002 Ω/Ω. Equal in each lead

## Product Certifications

### Approved Manufacturing Locations

Emerson Process Management Rosemount Division—  
Chanhassen, Minnesota, USA  
Rosemount Temperature GmbH – Germany  
Emerson Process Management Asia Pacific – Singapore

### European Union Directive Information

The EC declaration of conformity for all applicable European directives for this product can be found on the Rosemount website at [www.rosemount.com](http://www.rosemount.com). A hard copy may be obtained by contacting our local sales representative.

#### ATEX Directive (94/9/EC)

Rosemount Inc. complies with the ATEX Directive.

#### Electro Magnetic Compatibility (EMC) (89/336/EEC)

144 Temperature Transmitter and 144C Configuration Unit –  
EN 50081-1: 1992; EN 50082-2:1995;

### Hazardous Locations Certificates

#### North American Certifications

##### Factory Mutual (FM) Approvals

- K5 Combination Factory Mutual Intrinsically safe and Explosion-proof Approvals  
Intrinsically Safe for Class I, Division 1; Groups A, B, C, D.  
Non-incendive for Class I, Division 2, Groups A, B, C, D when installed in accordance with Rosemount Installation Drawing 00144-0110. Ambient temperature limits are between –40 and 85 °C. FM Entity Parameters are listed on the installation drawing (00144-0110) identified on the transmitter approval label.  
Explosion Proof for Class I, Division 1; Groups B, C, D. Dust ignition proof for Class II, Division 1, Groups E, F, and G. Dust ignition proof for Class III, Division 1 hazardous locations when installed in accordance with Rosemount drawing 00144-0130. A conduit seal is not required for compliance with NEC 501-5a(1).  
T5 ( $T_{amb} = -40$  to 85 °C)

#### NOTE

Approval K5 is only available with enclosure codes J5 or J6.

##### Canadian Standards Association (CSA) Approvals

- C6 Combination of CSA Intrinsically Safe, Nonincendive, and Explosion-Proof: Explosion-Proof for Class I, Division 1, Groups B, C, and D. Dust-ignition proof for Class II, Division 1, Groups E, F, and G. Dust-ignition proof for Class III, Division 1 hazardous locations when installed in accordance with Rosemount Drawing 00144-0140 factory sealed. Suitable for Class I, Division 2, Groups A, B, C, and D.  
Intrinsically Safe for Class 1, Division 1, Groups A, B, C, and D when installed per Rosemount drawing 00144-0120. Temperature codes: T4 ( $T_{amb} = -40$  to 85 °C);  
T6 ( $T_{amb} = -40$  to 60 °C)

#### NOTE

Approval C6 is only available with enclosure codes J5 or J6.

### European Certifications

#### CENELEC ATEX Approvals

- I1 Intrinsically Safe Certification  
DEMKO 00 ATEX 129255  
ATEX Marking: Ⓢ II 1 G  
EEx ia IIC T6 ( $T_{amb} = -40$  to 60 °C)  
EEx ia IIC T4 ( $T_{amb} = -40$  to 85 °C)  
Entity Parameters:  $U_i = 28$ VDC,  $I_i = 120$  mA,  $L_i = 10$  μH,  $C_i = 1$  nF,  $P_i = 0.84$ W

#### Directives:

ATEX: 94/9/EC

EMC: 89/336/EEC

Special Conditions for Safe Use (x):

- For correct use and installation the manufacture's manual must be followed.
- The apparatus must be installed in an enclosure with an Ingress Protection of at least IP20.
- The terminals 1 and 2 of the equipment have to be electrically connected to a barrier located in the non-hazardous area.
- The transmitter may only be used with transducers complying with "Simple Apparatus" according to EN 50020 Clause 5.4.

#### ED Flameproof Certification

KEMA 99 ATEX 8715  
ATEX Marking: Ⓢ II 2 G  
EEx d IIC T6 ( $T_{amb} = -40$  to 65 °C)  
Maximum Input Voltage: 42.4 V

#### Directives:

ATEX: 94/9/EC

#### NOTE

Only available with enclosure codes J5 or J6.

### Combination Certifications

- KC Combination Factory Mutual/CSA Intrinsically Safe Approval

**Factory Mutual-** Intrinsically Safe for Class I, II, III: Div. 1, Groups A, B, C, D. Non-incendive for Class I, Division 2, Groups A,B,C,D, when installed in accordance with Rosemount Installation Drawing 00144-0110. Ambient temperature limits are between –40 C and 85 °C. FM Entity Parameters are listed on the installation drawing.

**CSA-** Intrinsically Safe for Class I, Division 1, Groups A, B, C, D when connected in accordance with Rosemount Installation Drawing 00144-0120. T<sub>4</sub> (–40 °C ≤ T<sub>a</sub> ≤ 85 °C), T<sub>6</sub> (–40 °C ≤ T<sub>a</sub> ≤ 60 °C).

## Dimensional Drawings

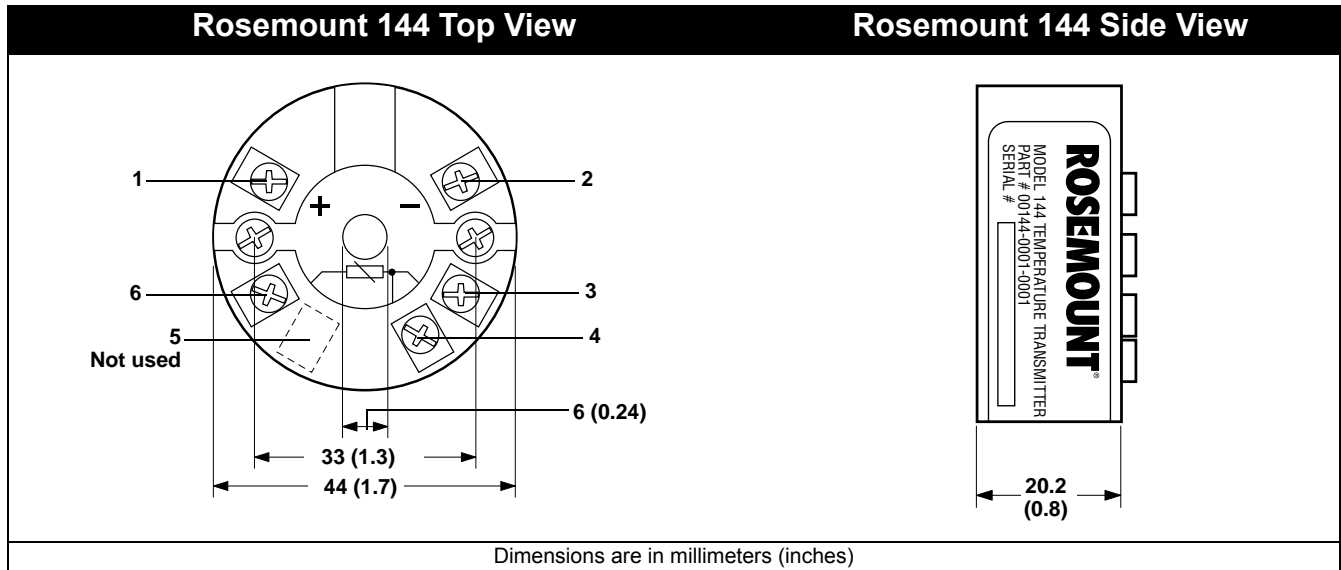

144-1442C03A, 04A

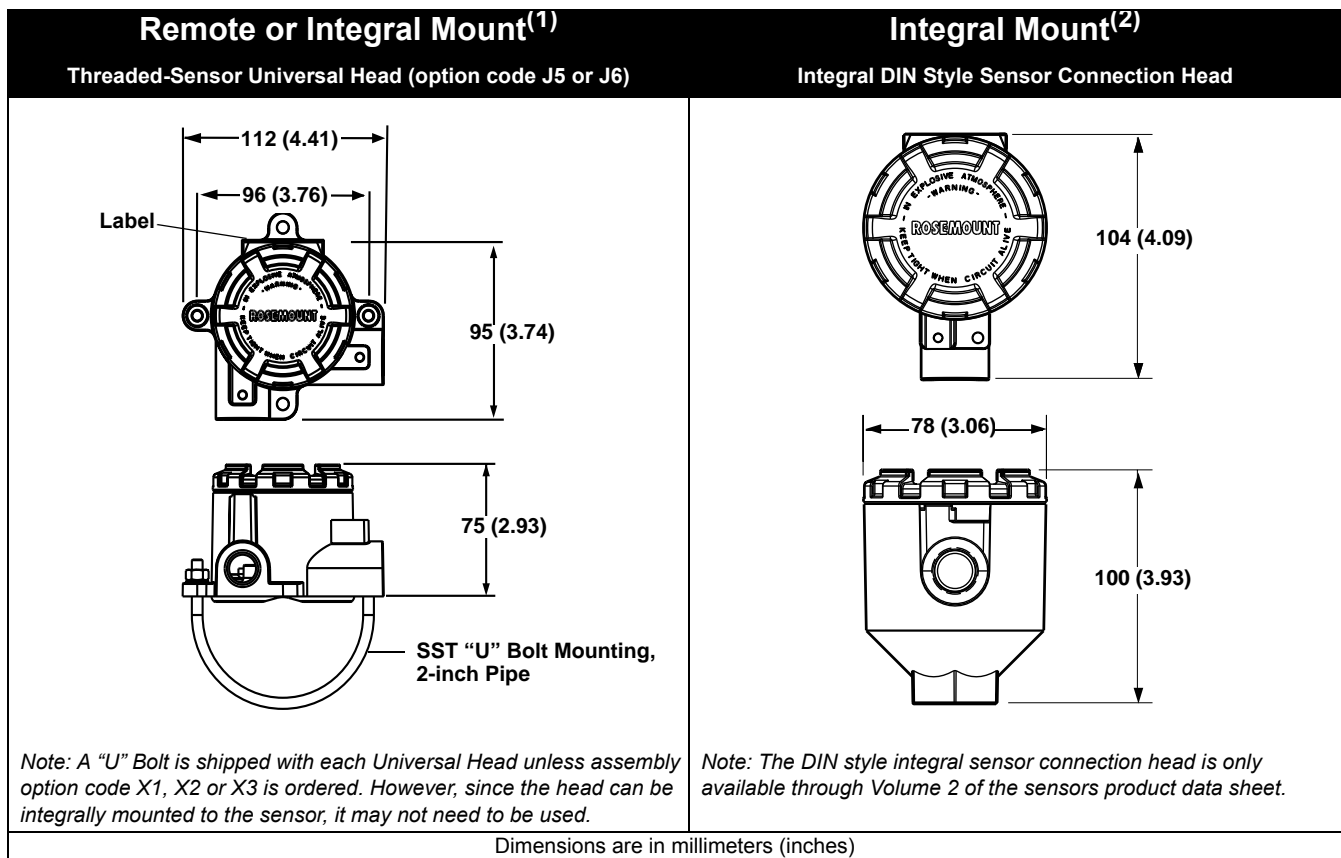

644-14420A01A, 4410A01A

(1) The Rosemount 144 remote or integral mount is to be ordered through the 144 model structure.  
 (2) The Rosemount 144 integral mount is to be ordered through the sensor model structure.

# Model 144H

## DIN Rail Mounting Kit

### Dimensions

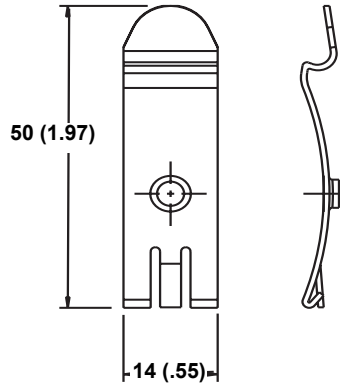

### Application

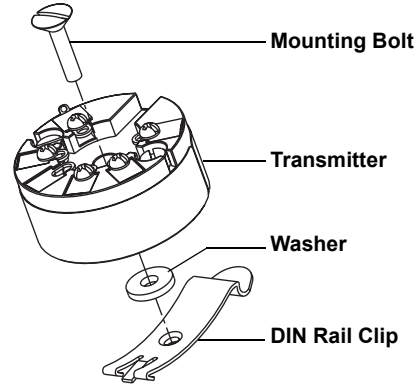

Dimensions are in millimeters (inches)

144-144C06A, 05A

## Rosemount 144C Configuration Interface Programmer

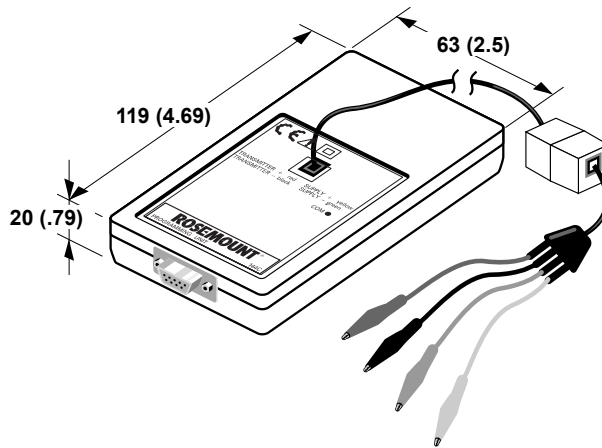

Dimensions are in millimeters (inches)

144-144-C07A

## Ordering Information

TABLE 1. Rosemount 144 PC-Programmable Temperature Transmitter

Model	Product Description	
144H	PC-Programmable Head Mount temperature transmitter	
Code	Hazardous Area Certifications	Enclosure Purchase Required?
I1 <sup>(1)</sup>	CENELEC intrinsic safety approval	No
KC <sup>(1)</sup>	FM/CSA intrinsic safety and non-incendive approval combination	No
ED <sup>(2)</sup>	CENELEC/KEMA flameproof approval	Yes
C6 <sup>(2)</sup>	CSA intrinsic safety, non-incendive, and explosion-proof approval combination	Yes
K5 <sup>(2)</sup>	FM intrinsic safety, non-incendive, and explosion-proof approval combination	Yes
NA	No approval	No
Code	Options	
<b>Assembly<sup>(3)</sup></b>		
X1	Assemble transmitter to a sensor assembly (hand tight, Teflon <sup>®</sup> (PTFE) tape where appropriate, fully wired)	
X2	Assemble transmitter to a sensor assembly (hand tight, no Teflon (PTFE) tape, unwired)	
X3	Assemble transmitter to a sensor assembly (wrench tight, Teflon (PTFE) tape where appropriate, fully wired)	
<b>Enclosure</b>		
J5 <sup>(4)</sup>	Universal Head, aluminum alloy with 50.8 mm (2-in.) Stainless Steel pipe bracket (M20 NPT entries)	
J6	Universal Head, aluminum alloy with 50.8 mm (2-in.) Stainless Steel pipe bracket (1/2–14 NPT entries)	
<b>Configuration<sup>(5)</sup></b>		
CN	Analog output levels compliant with NAMUR recommendation NE43. Set to fail low at factory.	
<b>Typical Model Number: 144H I1 X1 J6</b>		

- (1) Transmitters with intrinsic safety approvals can be ordered without an enclosure. However, to meet intrinsic safety requirements, the transmitter must be installed with an enclosure with IP20 or higher rating. Rosemount 144 transmitters that are ordered with enclosure options J5 or J6 meet this requirement.
- (2) Available only with enclosure options J5 or J6.
- (3) If ordering the X1, X2, or X3 option, specify the same code on the sensor model number. Option codes X1 and X3 are not available with CSA approvals (Hazardous Area Certifications C6).
- (4) Enclosure for remote mounting purposes. Sensor assembly options X1, X2, and X3 are not available.
- (5) Acceptable RTD input types are Pt 100, Ni 100, linear resistance (W) only. Factory default configuration is a 3-wire Pt 100, 0 to 100 °C (32 to 212 °F). If not configuration information is specified by the customer, the transmitter will be configured to the factory default configuration. Output levels compliant with NAMUR recommendations NE43; set fail high (upscale) at factory.

TABLE 2. Rosemount 144C Configuration Interface Hardware and Software

Model	Product Description
144C	Configuration interface hardware and software (programming unit, computer port connection cable, converter, and CD-ROM)

TABLE 3. Transmitter Accessories

Product Description	Part Number
DIN rail mounting kit	00144-0020-0001

# Product Data Sheet

00813-0100-4796, Rev DB  
February 2004

# Model 144H

## Rosemount 144C Configuration Interface

The Rosemount 144C Configuration Interface is a portable, self-contained communication link between your PC and the 144 transmitter for use in non-hazardous environments. The 144C Configuration Interface contains the following items:

- programming unit
- 9 pin com port connection wire
- 25 pin to 9 pin converter
- programming software (CD ROM)

## Rosemount 144C Configuration Software

The software makes the following parameters available:

- sensor type
- response time (damping)
- sensor error action (failure mode)
- linearization
- upper and lower range values
- transmitter tag number (electronic tag)
- temperature units (Celsius, Fahrenheit, Kelvin, Rankine)

Software for the 144C Configuration Interface is available in English and German. The table below shows the recommended computer hardware and software for complete functionality of the 144C Configuration Interface software.

Hardware/Software	Minimum Requirements
IBM compatible PC	Pentium processor
Memory	16 MB memory
Hard drive	10 MB
Display (Monitor)	CGA, HCG, EGA, VGA
Resolution	800 x 600
Operating System	Microsoft® Windows® 95, Windows 98, or Windows NT

*Rosemount and the Rosemount logotype are registered trademarks of Rosemount Inc.  
HART is a registered trademark of the HART Foundation  
FOUNDATION is a trademark of the Fieldbus Foundation.  
Teflon is a registered trademark of E.I. du Pont de Nemours & Co.  
Microsoft and Windows is a registered trademark of Microsoft, Inc.  
All other marks are the property of their respective owners.*

## Emerson Process Management

### Rosemount Inc.

8200 Market Boulevard  
Chanhassen, MN 55317 USA  
T (U.S.) 1-800-999-9307  
T (International) (952) 906-8888  
F (952) 949-7001

www.rosemount.com



### Rosemount Temperature GmbH

Frankenstrasse 21  
63791 Karlstein  
Germany  
T 49 (6188) 992 0  
F 49 (6188) 992 112

### Fisher Rosemount

Singapore Pte Ltd.  
1 Pandan Crescent  
Singapore 128461  
T (65) 777 8211  
F (65) 777 0947  
AP.RMT-Specialist@emersonprocess.com