

Rosemount 1199 Diaphragm Seal Systems

(European Offering)

FOR ROSEMOUNT 3051, 1151, AND 2088 TRANSMITTERS

EXPANDED TRANSMITTER USE

- *Extreme hot and cold temperatures*
- *Corrosive applications*
- *Clogging*
- *Sanitary requirements*

APPLICATIONS

- *Level, Flow, Pressure, Interface, Density*



Contents

Specifications	page 2
General Purpose Seals Selection Overview	page 5
Ordering Information	page 10
Diaphragm Seal Connections	page 11
General Purpose Seal Assemblies	page 13
Sanitary Diaphragm Seal Systems	page 32
General Information	page 43

Specifications

FILL FLUID SPECIFICATIONS

TABLE 1. Fill Fluid Specifications

Fill Fluid	Temperature Limits ⁽¹⁾		Specific Gravity	Coeff. of Therm. Exp. (cc/cc/°C)	Viscosity at 25 °C centistokes	Recommended Capillary I. D.
	Pabs < 1 bara	Pabs > 1 bara				
D.C.200 Silicone	-45 to 100 °C	-45 to 205 °C	0,93	0,00108	9,5	All
Inert (Halocarbon)	-45 to 80 °C	-45 to 160 °C	1,85	0,000864	6,5	All
Syltherm XLT Silicone	NA	-75 to 150 °C	0,85	0,001199	1,6	All
Neobee M-20 ⁽²⁾	-15 to 120 °C	-15 to 225 °C	0,90	0,001008	9,8	All
D.C.704 Silicone ⁽³⁾	-20 to 200 °C	-20 to 315 °C	1,07	0,0008	39,0	2 mm
Vegetable, Sanitary Oil	-10 to 120 °C	-10 to 250 °C	0,91	0,0008	63,0	2 mm

- (1) Temperature limits are reduced in vacuum service and may be limited by seal selection. Contact an Emerson Process Management representative for assistance.
- (2) Select sanitary fill fluid for sanitary applications requiring faster response times.
- (3) Upper temperature limit is for capillary seal systems mounted away from the transmitter. Contact an Emerson Process Management representative for temperature limits above 315 °C.

MINIMUM SPAN RECOMMENDATIONS

Table 2 lists minimum span recommendations in mbar for Rosemount pressure transmitters as a function of the diameter of the diaphragm seal. Contact an Emerson Process Management representative for minimum calibrated span recommendation for all in-line seal designs or seals with diameter less than 25mm.

These recommendations are based on the following:

- Stainless steel diaphragm; standard thickness.
- Single-sided capillary length up to 5 m.
- The diameter of the pressure sensor smaller than the diameter of the diaphragm seal.
- Differential pressure systems are balanced.

Consult Instrument ToolKit™ software or contact an Emerson Process Management representative for a more detailed performance evaluation of diaphragm seal systems.

TABLE 2. Minimum Span Recommendations (mbar)

F.A. = Factory Approval required

dm (mm)	Differential Pressure		Gauge Pressure		Absolute Pressure	
	2 mm Cap ID	1 mm Cap ID	2 mm Cap ID	1 mm Cap ID	2 mm Cap ID	1 mm Cap ID
25	F.A.	F.A.	5000	5000	F.A.	F.A.
32	F.A.	F.A.	2500	2000	F.A.	F.A.
40	750	500	1500	1000	F.A.	F.A.
57	100	75	500	300	1000	750
76	25	20	150	100	500	350
89	4	3	20	20	20	20

INDUSTRY STANDARDS

Tables 3 and 4 list industry standards and their descriptions for General Purpose and Sanitary Seals.

TABLE 3. Available Industry Standards for General Purpose Diaphragm Seals

Standard	Description
DIN 2512 Form F	Tongue
DIN 2512 Form N	Groove
DIN 2513 Form R-13	Large female face
DIN 2513 Form V-13	Large male face
DIN 2514 Form V-14	Male face
DIN 2514 Form R-14	Female face

TABLE 3. Available Industry Standards for General Purpose Diaphragm Seals

Standard	Description
DIN 2526 Form C, D or E	Raised face
DIN 2696 Form L	'Linsen" gasket face
ANSI /ASME B16.5	Raised face
ANSI /ASME B16.5	Ring type joint

TABLE 4. Available for Sanitary Diaphragm Seals Industry Standards⁽¹⁾

Standard	Description
SMS: Swedish Milk Standard	Female or male thread
IDF: International Dairy Federation	Female or male thread
RJT: Ring Joint Type	Female or male thread
DIN 11851	Female or male thread
Tri-Clamp®	Sanitary
Tuchenhagen Varivent®	Sanitary
Homogenizer Clamping Flange	Sanitary

(1) Other standards are available upon request.

GASKET SPECIFICATIONS

Table 5 refers to the gaskets supplied with the diaphragm seal.

TABLE 5. Gasket Specifications

Gasket	Temperature Limit (°C)
PTFE ⁽¹⁾	-160 to 230 °C
98% Graphite ⁽¹⁾	-200 to 500 °C
Viton® ⁽²⁾	-20 to 200 °C
Ethylene Propylene	-55 to 150 °C

(1) Temperature limits are in standard circumstances.

(2) Temperature limit in oxidizing atmosphere.

TRANSMITTER SPECIFICATIONS

Functional Specifications

For complete functional, performance, and physical specifications for the Rosemount 3051S, 3051C, Rosemount 3051T, Rosemount 1151, and Rosemount 2088 transmitters, refer to the respective product data sheets listed in this section.

The transmitter pressure ranges and ordering codes for use with diaphragm seals are located in Section 4 of this document.

TABLE 6. Transmitter Temperature Limits Summary.

	Rosemount 3051S, 3051C, 3051T	Rosemount 1151	Rosemount 2088
Ambient	-40 to 85 °C	S Electronics -40 to 85 °C E,G Electronics -30 to 95 °C	-40 to 85 °C
Storage	-45 to 110 °C	S Electronics -50 to 85 °C E,G Electronics -50 to 120 °C	-45 to 85 °C
Process Silicone Sensor	-40 to 120 °C	-40 to 105 °C	-40 to 120 °C

Hazardous Locations Certifications

Adding seals to the transmitter does not change the approval ratings of the individual transmitters. For complete approval listings, see the respective product data sheet for the pressure transmitter.

Maximum Working Pressure of Transmitter–Seal System

The maximum working pressure (MWP) of the transmitter–seal system is a function of the MWP of the transmitter and the remote seal. To determine the MWP of the transmitter–seal system, simply select the lesser value of the two. For safe operation, the MWP of the transmitter–seal system must not be exceeded.

Rosemount 1199

NACE Standard

NACE (National Association of Corrosion Engineers) standard MR-01-75 defines metallic material requirements for resistance to sulfide stress cracking when exposed to sour environments. Contact an Emerson Process Management representative to aid in selecting the proper materials in order for Rosemount diaphragm seals to meet the NACE standard.

Zero Elevation and Suppression

Zero elevation and suppression must be such that the lower range value is greater than or equal to the (-URL) and the upper range value is less than or equal to the (+URL). The calibrated span must be greater than or equal to the minimum span.

PHYSICAL SPECIFICATIONS

Materials of Construction

Isolating Diaphragm

Rosemount 3051S/C: 316L SST
 Rosemount 3051T: 316L SST
 Rosemount 1151: 316L SST
 Rosemount 2088: 316L SST

Process Flange or Connector

Rosemount 3051S/C: 316 SST
 Rosemount 3051T: 316L SST
 Rosemount 1151: CF-8M (Cast Version of 316 SST, material per ASTM-A743)
 Rosemount 2088: 316L SST

O-ring

Rosemount 3051S/C: Glass-filled TFE
 Rosemount 3051T: None
 Rosemount 1151: Viton or Buna N
 Rosemount 2088: None

Sensor Module Fill Fluid

Silicone Oil

Bolts (Rosemount 3051S/C and 1151 only)

Plated Carbon Steel or 316 SST

Electronics Housing

Low-copper aluminum or CF-8M (cast version of 316 SST, material per ASTM-A743), NEMA 4X, IP66

Paint

Polyurethane

Cover O-rings

Buna-N

Electrical Connection

Rosemount 3051S, 3051C, 3051T, and Rosemount 2088

1/2-14 NPT, PG 13.5, G¹/₂ Female (PF¹/₂ Female, or M20 3
 1.5 Female (CM20) conduit entry

Rosemount 1151

- 1/2-14 NPT conduit with screw terminals and integral test jacks compatible with miniature banana plugs (Pomona 2944, 3690, or equivalent)

Rosemount 3051S, 3051C, 3051T, and Rosemount 1151 Smart

- The *HART*[®]-based communicator connections are fixed to the terminal block.

Transmitter Weight

The transmitter/seal system weight depends on the type of capillary and seal:

Rosemount 3051S_C

3,3 kg without options

Rosemount 3051C

2,5 kg without options

Rosemount 3051T

1,4 kg without options

Rosemount 1151

5,5 kg without options

Rosemount 2088

1,0 kg without options

Tagging

The pressure transmitter will be tagged, at no charge, in accordance with customer requirements. All tags are stainless steel. The standard tag is wired to the transmitter. Tag is 0,5 mm thick with 3,2 mm high letters. A permanently attached tag is available upon request. The remote seal model number is identified on the transmitter nameplate

Calibration

Transmitters are factory calibrated to customer's specified range. If calibration is not specified, then the transmitters are calibrated at maximum range. Calibration is performed at ambient temperature and pressure. Four and 20 mA points must be the same unit of measure. Available units of measure:

- | | | | | |
|----------------------|--------|----------------------|--------|--------|
| • inH ₂ O | • bar | • kg/cm ² | • atm | • kPa |
| • mmH ₂ O | • mbar | • g/cm ² | • psi | • inHg |
| • ftH ₂ O | • Pa | • torr | • mmHg | |

Custom Configurations

Rosemount 3051S/3051C (Option Code C1)

If code C1 is ordered, the customer may specify the following data in addition to the standard configuration parameters. Refer to Configuration Data Sheet 00806-0100-4001.

Rosemount 1151 (Option Code C9)

If Options Code C9 is ordered, the customer may specify the following data in addition to the standard configuration parameters. Refer to Configuration Data Sheet 00806-0100-4593.

Descriptor: 16 alphanumeric characters





Message: 32 alphanumeric characters

Date: Day, month, year





Damping: Sec.



General Purpose Seals Selection Overview



Diaphragm Seal Selection Guides

Diaphragm Seal Selection Guide				
				
Seal Type	Flush Flanged Type (FFW, FUW.) (see 00813-0100-4016)	RTJ Flush Flanged Type (FCW) (see 00813-0100-4016)	Extended Flanged Type (EES, EFS) (see page 13)	Flush Pancake (Cell) Type (PFS) (see page 17)
Usual Application and Type of Service	General Applications	High Pressure Applications	Insulated Processes	General Applications
Gasket Surface Type	DIN 2526 Form D DIN 2526 Form E ANSI/ASME B16.5 Serrated Finish ANSI/ASME B16.5 Smooth Finish DIN 2512 Form F DIN 2512 Form N DIN 2513 Form V-13 DIN 2513 Form R-13 DIN 2514 Form V-14 DIN 2514 Form R-14	ANSI/ASME B16.5 RTJ	DIN 2526 Form D DIN 2526 Form E ANSI/ASME B16.5 Serrated Finish ANSI/ASME B16.5 Smooth Finish	DIN 2526 Form D DIN 2526 Form E ANSI/ASME B16.5 Serrated Finish ANSI/ASME B16.5 Smooth Finish
Process Connection Size	DN 25 1 in. DN 40 1 1/2 in. DN 50 2 in. DN 80 3 in. DN 100 4 in.	1 in. 1 1/2 in. 2 in. 3 in. 4 in.	. DN 50 2 in. DN 80 3 in. DN 100 4 in.	DN 25 1 in. DN 40 1 1/2 in. DN 50 2 in. DN 80 3 in. DN 100 4 in.
Flange Pressure Rating	PN 16 Class 150 PN 40 Class 300 PN 64 Class 400 PN 100 Class 600 PN 160 Class 900 PN 250 Class 1500 PN 400 Class 2500	Class 150 Class 300 Class 400 Class 600 Class 900 Class 1500 Class 2500	PN 16 Class 150 PN 40 Class 300 PN 64 Class 400 PN 100 Class 600 PN 160 Class 900 PN 250 Class 1500 PN 400 Class 2500	PN 16-400 Class 150–2500

Rosemount 1199

Diaphragm Seal Selection Guide				
				
Diaphragm and Wetted Parts Material/ Upper Housing Material	316LSST <i>Monel 400</i> [®] 316Ti SST (WNR 1.4571) Titanium Gr2 <i>Hastelloy</i> [®] C-276,B,C-22 Zirconium <i>Inconel 600</i> [®] Tantalum Nickel 201	316LSST 316Ti SST (WNR 1.4571) <i>Hastelloy C-276</i> Duplex SST 1.4462	316LSST Nickel 201 316Ti SST (WNR 1.4571) <i>Monel 400</i> <i>Hastelloy C-22, C-276, B</i> <i>Inconel 600</i> Tantalum Titanium Gr2	316LSST Nickel 201 316Ti SST (WNR 1.4571) Titanium Gr2 <i>Hastelloy C-276, B, C-22</i> <i>Monel 400</i> Zirconium Tantalum <i>Inconel 600</i>
Flushing Ring Material	316L SST 316Ti SST (WNR 1.4571) <i>Hastelloy C-276</i> Duplex SST 1.4462	316L SST 316Ti SST (WNR 1.4571) <i>Hastelloy C-276</i> Duplex SST 1.4462	Not Applicable	316L SST 316Ti SST (WNR 1.4571) <i>Hastelloy C-276</i> Duplex SST 1.4462
Options	Direct Mount Connection Material Traceability Gold-coated 5 μm <i>Teflon</i> [®] -coated Diaphragm Cold Temperature Fill 50 μm Diaphragm Thickness 150 μm Diaphragm Thickness	Direct Mount Connection Material Traceability <i>Teflon</i> -coated Diaphragm Cold Temperature Fill 50 μm Diaphragm Thickness 150 μm Diaphragm Thickness	Direct Mount Connection Material Traceability Custom Extension Lengths Cold Temperature Fill 50 μm Diaphragm Thickness 150μm Diaphragm Thickness	Material Traceability Cold Temperature Fill Gold-coated 5 μm <i>Teflon</i> -coated Diaphragm 50 μm Diaphragm Thickness 150μm Diaphragm Thickness

Diaphragm Seal Selection Guide			
			
Seal Type	Extended Pancake (Cell) Type (DES, DFS) (see page 20)	Internal Flanged Type (RFW) (see 00813-0100-4016)	Internal Threaded Type (RTW) (see 00813-0100-4016)
Usual Application and Type of Service	Insulated Processes	Small Process Connections	Small Process Connections High Pressures
Gasket Surface Type	DIN 2526 Form D DIN 2526 Form E ANSI/ASME B16.5 Serrated Finish ANSI/ASME B16.5 Smooth Finish DIN 2512 Form N DIN 2512 Form F DIN 2513 Form V-13 DI 2513 Form R-13 DIN 2514 Form V-14 DIN 2514 Form R-14	DIN 2526 Form D DIN 2526 Form E ANSI/ASME B16.5 Serrated Finish ANSI/ASME B16.5 Smooth Finish	Not Applicable

Diaphragm Seal Selection Guide			
			
Process Connection Size	DN 50 2 in. DN 80 3 in. DN 100 4 in. DN 125 5 in.	DN 20 1/2 in. DN 25 3/4 in. DN 32 1 1/4 in. DN 40 1 1/2 in.	Parallel Thread: G 1/2A DIN 16288 Tapered Thread: R 1/2A per ISO 7/1 1/2-14 NPT 1-11.5 NPT
Flange Pressure Rating	PN 16-400 Class 150-2000	PN 40 Class 150 PN 64 Class 300 PN 100 Class 600 PN 160	PN 40 PN 100 PN 250
Diaphragm and Wetted Parts Material	316LSST Nickel 201 316Ti SST (W Nr 1.4571) Monel 400 Inconel 600 Tantalum Titanium Gr2 Hastelloy C-276, C-22, B	316LSST Nickel 201 316Ti SST (W Nr 1.4571) Monel 400 Inconel 600 Tantalum Hastelloy C-276, C-22, B Titanium Gr 2	316LSST Monel 400 316Ti SST (W Nr 1.4571) Tantalum Inconel 600 Nickel 201 Hastelloy C-276, C-22, B Titanium Gr 2
Lower Housing (Flushing) Material	Not Applicable	Hastelloy C-276 316L SST 316Ti SST (W Nr 1.4571)	Hastelloy C-276 316L SST 316Ti SST (W Nr 1.4571)
Options	Material Traceability Teflon -coated Diaphragm Cold Temperature Fill 50 µm Diaphragm Thickness 150 µm Diaphragm Thickness Custom Extension Lengths	Direct Mount Connection Material Traceability Gold-coated 5 µm Teflon -coated Diaphragm Cold Temperature Fill 50 µm Diaphragm Thickness 150 µm Diaphragm Thickness Teflon -lined Lower Housing	Direct Mount Connection Material Traceability Teflon -coated Diaphragm Cold Temperature Fill 50 µm Diaphragm Thickness 150 µm Diaphragm Thickness

Diaphragm Seal Selection Guide			
			
Seal Type	Threaded Flush Type (HTS) (see page 23)	In-Line Cell Type (TFS) (see page 25)	Extruder Flanged Type (JES) (see page 31)
Usual Application and Type of Service	High Process Pressures Chemical, Food, Paint, Pulp and Paper Industries	Eliminate Process Dead Ends High Viscosity Fluids	Plastic Extrusion High Temperature
Gasket Surface Type	Dependent on Thread Type	DIN 2526 Form D DIN 2526 Form E ANSI/ASME B16.5 Smooth and Serrated Finish	Extrusion Clamping Flange
Process Connection Size	G1 1-11.5 NPT G1 1/2 1 1/2-11.5 NPT G2 2-11.5 NPT	DN 25 1 in. DN 40 1 1/2 in. DN 50 2 in. DN 80 3 in. DN 100 4 in.	Special for Extruders

Rosemount 1199

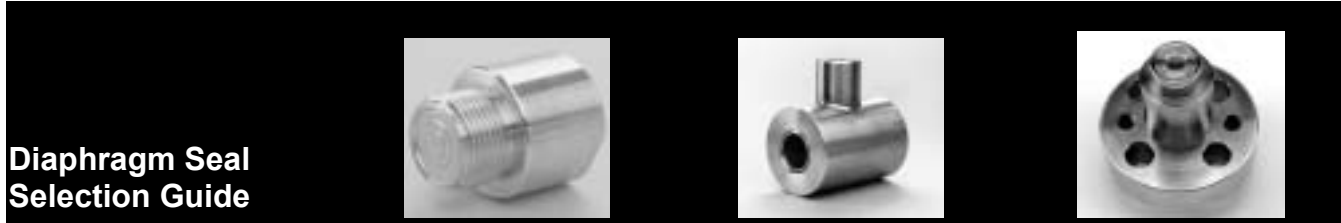

Diaphragm Seal Selection Guide

Pressure Rating	600 Bar	PN 16-400 Class 150-2500	400 bar
Diaphragm and Wetted Parts Material/ Upper Housing Material	316L SST 316Ti SST (WNR 1.4571)	316L SST 316Ti SST (WNR 1.4571)	316L SST 316Ti SST (WNR 1.4571)
Options	Material Traceability Cold Temperature Fill 50 µm Diaphragm Thickness 150 µm Diaphragm Thickness Direct Mount	Material Traceability Integral Flange Construction Direct Mount to Rosemount 3051T or Rosemount 2088	Material Traceability 150 µm Diaphragm Thickness Custom Extension Lengths Jock Screws Direct Mount

Sanitary Seal Selection Overview



Sanitary Seal Selection Guide

Seal Type	In-Line Sanitary Type (VLS, VMS) (see page 32)	Dairy Type (SLS, SMS, SFS, SRS) (see page 34)	Dairy Type (MLS, MMS, MFS, MRS) (see page 36)	In-Line Sanitary <i>Tri-Clamp</i> (VCS) (see page 38)
Usual Application and Type of Service	Food and Pharmaceutical Industries High Viscosity Fluids Eliminate Process Dead Ends	Sanitary and Food Industry	Sanitary and Food Industry	Food and Pharmaceutical Industries High Viscosity Fluids Eliminate Process Dead Ends
Connection Type	DIN 11851 Male SMS Male	DIN 11851 Female SMS Female IDF Female RJT Female	DIN 11851 Male SMS Male IDF Male RJT Male	<i>Tri-Clamp</i>
Process Connection Size	DN 25 1 in. DN 40 1 1/2 in. DN 50 2 in. DN 80 3 in. DN 100 4 in.	DN 25 DN 65 DN 32 DN 80 DN 40 DN 100 DN 50	DN 25 DN 65 DN 32 DN 80 DN 40 DN 100 DN 50	DN 25 1 in. DN 40 1 1/2 in. DN 50 2 in. DN 80 3 in. DN 100 4 in.
Pressure Rating	40 bar	40 Bar	40 Bar	40 Bar
Diaphragm Material	316L SST 316Ti SST (WNR 1.4571)	316L SST 316Ti SST (WNR 1.4571)	316L SST 316Ti SST (WNR 1.4571)	316L SST 316Ti SST (WNR 1.4571)
Options	Electro-polished Diaphragm Material Traceability	Electro-polished Diaphragm Material Traceability	Electro-polished Diaphragm Material Traceability	Material Traceability Electro-polished Diaphragm

Sanitary Seal Selection Guide				
				
Seal Type	Sanitary <i>Tri-Clamp</i> Type (SCS) (see page 39)	Sanitary Tank Spud Type (EES) (see page 40)	Tuchenhagen <i>Varivent</i> Compatible Connection (see page 41)	Homogenizer Clamping Flange (CHS) (see page 42)
Usual Application and Type of Service	Sanitary and Food Industry	Sanitary and Food Industry	Sanitary and Food Industry	Homogenizers
Process Connection Size	<i>Tri-Clamp</i>	Spud-Ring with Ethylene-Propylene O-ring Standard	Tuchenhagen <i>Varivent</i>	Special for Homogenizers
Pressure Rating	40 bar	40 bar	40 bar	600 bar
Diaphragm Material	316L SST 316Ti SST (Wnr 1.4571)	316L SST 316Ti SST (Wnr 1.4571) <i>Hastelloy C-276</i>	316L SST 316Ti SST (Wnr 1.4571)	316L SST
Options	Electro-polished Diaphragm Material Traceability Counterpiece, Gasket and Clamp	Electro-polished Diaphragm Material Traceability Counterpiece and Gasket	Electro-polished Diaphragm Material Traceability Counterpiece and Gasket	Material Traceability 150 μm Diaphragm Thickness

Ordering Information

HOW TO ORDER A ROSEMOUNT SEAL/TRANSMITTER SYSTEM

The following steps outline the transmitter/seal system ordering process. Please review the entire procedure before specifying a transmitter/seal system model number.

Step 1. Select a Pressure Transmitter Model Number

Refer to the Pressure Transmitters product data sheets below to select a transmitter model number.

For additional transmitter information, see the following product data sheets:

- Rosemount 3051S Series:
(document number 00813-0100-4801)
- Rosemount 3051C and 3051T
(document number 00813-0100-4001)
- Rosemount 2088
(document number 00813-0100-4690)
- Rosemount 1151
(document number 00813-0100-4360)

Step 2. Select a Seal Assembly Model Number

1. Use Table 7 on page 11 or Table 8 on page 12 to specify a Capillary or Direct Mount Fill Fluid code (nine characters).
 - Include a code from each section of the table.

Example: Using: "1199MD256..." is typical of the first half of a seal assembly model number.
2. Use the Seal tables beginning on page 11 to specify the Diaphragm Seal Configuration.
3. Include a code from each section of the table.
 - Include as many options as desired from the Options (Multiple Selections) section.

Example: The customer wants the one piece design and a 150mm diaphragm thickness to add a vacuum resistant to the model. The model string becomes DFFWJG0A00EC.
4. Combine the two sets of model numbers to create one model number string. This completes a valid seal assembly model number.

Example: Combine the model strings in steps A and B above for a complete seal assembly model number string: "1199MD256 DFFWJG0A00EC."

NOTE FOR SPECIAL CONFIGURATIONS

It is possible to order two different seal assemblies for one transmitter. Use the seal location code to specify the attachment location for both the high and low side seals.

For example, suppose a direct mount seal is required on the high pressure side of the Rosemount 3051 All-Welded System and a seal with a 3 m capillary is required for the low pressure side. In this example, the order may look like the following:

Quantity	Model Number
1	3051CD4A22A1AS9 (From Step 1)
1	1199WDAD6 DFFWJGDA00 (From Step 2)
1	1199MD356 DFFWJGDA00 (From Step 2)

CAUTION

While it is possible to combine different types of seals, fill fluid and capillary lengths, be aware that performance may be more affected by some combinations than others. Consult with an Emerson Process Management representative for assistance in seal selection.

Diaphragm Seal Connections

Use Table 7 to order Capillary type connections. use Table 8 to order Direct Mount type connections.

Capillary/Fill Fluid

TABLE 7. Capillary/Fill Fluid Ordering Information⁽¹⁾

Model	Type
1199	Diaphragm Seal

Code	Seal Location	Connection Type ⁽²⁾	Transmitter Type
P ⁽³⁾	Seal on High Pressure Side of Transmitter	All welded system	Rosemount 3051T, 2088, and 3051S2T
R ⁽³⁾	Seal on High Pressure Side of Transmitter	All welded system	Rosemount 3051S_C (option code B11)
S ⁽³⁾	Seal on Low Pressure Side of Transmitter (use with Rosemount 1199T)	All welded system	Rosemount 3051S_C (option code B12)
T ⁽³⁾	Seal on High Pressure Side of Transmitter (requires Rosemount 1199S on low side)	All welded system	Rosemount 3051S_C (option code B12)
D	Same Seal on Both High and Low Pressure Sides of Transmitter	Welded	Differential Transmitter
W	Seal on High Pressure Side of Transmitter	Welded	All Transmitters
M	Seal on Low Pressure Side of Transmitter	Welded	Differential Transmitters

Code	Temperature Limits ⁽⁴⁾			Specific Gravity
	Fill Fluid	Pabs < 1 bara	Pabs > 1 bara	
D	D.C.200 Silicone	-45 to 100 °C	-45 to 205 °C	0,93
C	D.C. 704 Silicone	0 to 200 °C	0 to 315 °C	1,07
A	Syltherm XLT Silicone	N/A	-75 to 150 °C	0,85
H	Inert (Halocarbon)	-45 to 80 °C	-45 to 160 °C	1,85
N	Neobee M-20	-15 to 120 °C	-15 to 225 °C	0,90
4	Vegetable, Sanitary Oil	-10 to 120 °C	-10 to 250 °C	0,91

Code	Capillary Inside Diameter (mm)	Material
2	1 mm	SST Armored Sleeving and Support Tubes
3	2 mm	SST Armored Sleeving and Support Tubes
5	1 mm	SST Armored Polyethylene Sleeving and Support Tubes
6	2 mm	SST Armored Polyethylene Sleeving and Support Tubes

Code	Capillary Connection Length	Code	Capillary Connection Length
51	0,5 m	68	14,0 m
52	1,0 m	69	15,0 m
53	1,5 m	70 ⁽⁵⁾	16 m
54	2,0 m	71 ⁽⁵⁾	17 m
55	2,5 m	72 ⁽⁵⁾	18 m
56	3,0 m	73 ⁽⁵⁾	19 m
57	3,5 m	74 ⁽⁵⁾	20 m
58	4,0 m	75 ⁽⁵⁾	21 m
59	5,0 m	76 ⁽⁵⁾	22 m
60	6,0 m	77 ⁽⁵⁾	23 m
61	7,0 m	78 ⁽⁵⁾	24 m
62	8,0 m	79 ⁽⁵⁾	25 m
63	9,0 m	80 ⁽⁵⁾	26 m
64	10,0 m	81 ⁽⁵⁾	27 m
65	11,0 m	82 ⁽⁵⁾	28 m
66	12,0 m	83 ⁽⁵⁾	29 m
67	13,0 m	84 ⁽⁵⁾	30 m

(1) Shaded Areas indicate special orders. Consult an Emerson Process Management representative for configuration availability, performance effect, and lead time.

(2) See page 48 for more information on all welded systems.

(3) All welded system connection types require either a 316L SST or Hastelloy C-276 isolating diaphragm in the pressure transmitter model codes.

(4) Contact an Emerson Process Management representative for temperature limits above 315°C.

(5) Consult an Emerson Process Management representative to perform performance effect calculation.

Direct Mount Connection Type/Fill Fluid

TABLE 8. Direct Mount/Fill Fluid Ordering Information

Model	Type			
1199	Diaphragm Seal			
Code	Seal Location	Connection Type ⁽¹⁾		Transmitter Type
W	Seal on High Pressure Side of Transmitter	Welded		All Transmitters
P ⁽²⁾	Seal on High Pressure Side of Transmitter	All welded system		Rosemount 3051T, 2088, and 3051S2T
R ⁽²⁾	Seal on High Pressure Side of Transmitter	All welded system		Rosemount 3051S_C (option code B11)
T ⁽²⁾	Seal on High Pressure Side of Transmitter	All welded system		Rosemount 3051S_C (option code B12)
Code	Temperature Limits ⁽³⁾			
	Fill Fluid	Pabs < 1 bara	Pabs > 1 bara	Specific Gravity
D	D.C.200 Silicone	-45 to 100 °C	-45 to 205 °C	0,93
C	D.C.704 Silicone	0 to 200 °C	0 to 260 °C	1,07
A	Syltherm XLT Silicone	N/A	-75 to 150 °C	0,85
H	Inert (Halocarbon)	-45 to 80 °C	-45 to 160 °C	1,85
N	Neobee M-20	-15 to 120 °C	-15 to 225 °C	0,90
4	Vegetable, Sanitary Oil	-10 to 120 °C	-10 to 250 °C	0,91
Code	Connection Type			
A	Direct Mount Connection			
Code	Direct Mount Connection Type			

WELDED CONNECTION TYPE:

Rosemount 3051C and 3051S Transmitters (use with seal code W), 3051C Transmitter Option Code S1, or 3051S_C with B11 process connection code.

- B3 One Diaphragm Seal System, 50 mm Connection
- D3 One Diaphragm Seal System, 100 mm Connection

Rosemount 3051T Transmitter or 2088 Transmitter

- 95 One Diaphragm Seal System, 25 mm Connection, all welded (use with code P) or welded (use with code W)
- A5 One Diaphragm Seal System, 50 mm Connection

Rosemount 1151 Transmitter (use with seal code W)

- 92 One or Two Diaphragm Seal System. One Direct Mount, One Direct Mount and One Capillary Mount, or Two Capillary Mount Configuration Available

ALL WELDED CONNECTION TYPE:

Rosemount 3051C and 3051S all welded system (use with seal codes R or T), 3051C Transmitter Option Code S0 or 3051S_C with B11 process connection code

- B7 One Diaphragm Seal System, 50 mm Connection
- D7 One Diaphragm Seal System, 100 mm Connection

Rosemount 3051C (use with seal code W) Transmitter Option Code S2 or Rosemount 3051S_C with B12 process connection code

- B4 Two Diaphragm Seal System, 50 mm Direct Mount Connection and Capillary Connection
- D4 Two Diaphragm Seal System, 100 mm Direct Mount Connection and Capillary Connection

Rosemount 3051C Transmitter Option Code S9 or 3051S_C with B12 process connection code

- B6 Two Diaphragm Seal System, 50 mm Direct Mount Connection and Capillary Connection
- D6 Two Diaphragm Seal System, 100 mm Direct Mount Connection and Capillary Connection

Rosemount 3051T Transmitter or 2088 Transmitter

- 95 One Diaphragm Seal System, 25 mm Connection, all welded (use with code P) or welded (use with code W)
- A5 One Diaphragm Seal System, 50 mm Connection

(1) See page 48 for more information on all welded systems.

(2) All welded system connection types require either a 316L SST or Hastelloy C-276 isolating diaphragm in the pressure transmitter model codes.

(3) Fill fluid maximum operating temperature is limited by heat transfer to transmitter electronics. Process Temperature limit for Rosemount 3051C 100 mm Direct Mount system at 21 °C ambient temperature is 260 °C and 205 °C for all other direct mount connection types. The temperature limit for the Rosemount 1151 and 2088 Direct Mount systems is 205 °C.

General Purpose Seal Assemblies

EFS Flanged type: Extended Diaphragm Seals

Dimensional Drawing for EFS Flanged Type: Extended Diaphragm Seal

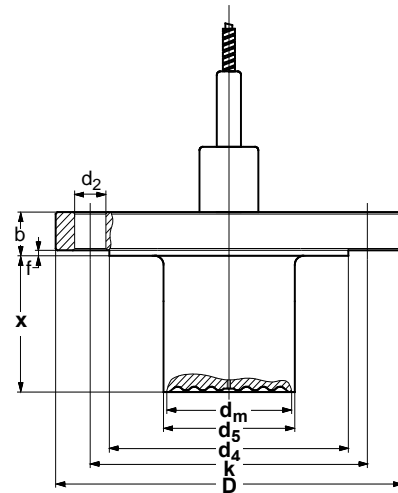

1199-070AB, 1199-0000A02A

EFS Process Connection Dimensions

		DIN 2501								ANSI/ASME B16.5									
DN	PN ⁽¹⁾	Dimensions (mm)								DN	CL ⁽¹⁾	Dimensions (mm)							
		dm	D	b	d2	k	f	d4	d5			dm	D	b	d2	k	f	d4	d5
50	40	40	165	20	4x18	125	3	102	48	2 in.	150	40	152	19	4x19	121	1,5	92	48
	64	40	180	26	4x22	135	3	102	48		300	40	165	22	8x19	127	1,5	92	48
	100	40	195	28	4x26	145	3	102	48		600	40	165	32	8x19	127	6,3	92	48
80	40	72	200	24	8x18	160	3	138	76	3 in.	150	72	190	24	4x19	152	1,5	127	76
	64	72	215	28	8x22	170	3	138	76		300	72	210	28	8x22	168	1,5	127	76
	100	72	230	32	8x26	180	3	138	76		600	72	210	38	8x22	168	6,3	127	76
100	16	89	220	20	8x18	180	3	158	96	4 in.	150	89	229	24	8x19	190	1,5	157	96
	40	89	235	24	8x22	190	3	162	96		300	89	254	32	8x22	200	1,5	157	96
	64	89	250	30	8x26	200	3	162	96		400	89	254	35	8x25	200	6,3	157	96

(1) Dimensions for other flange ratings are available upon request.

Standard Extension Lengths x ⁽²⁾	DIN Standard Extension Lengths x ⁽²⁾	ANSI/ASME Standard Extension Lengths x ⁽²⁾
50 mm	50 mm	2 in.
100 mm	100 mm	4 in.
150 mm	150 mm	6 in.
200 mm	200 mm	8 in.

(2) Other extension lengths are available upon request.

Rosemount 1199

TABLE 9. EES and EFS Flanged Type: Extended Diaphragm Seal – DIN Ordering Information⁽¹⁾

Code	Industry Standard		
D	DIN 2501 (Deutsches Institut für Normung)		
Code	Process Connection Style		
E	Flanged Type: Extended Diaphragm Seal		
Code	Gasket Surface Type		
FS	DIN 2526 Form D		
ES	DIN 2526 Form E ⁽²⁾		
Code	Process Connection Size		
G	DN 50		
J	DN 80		
K	DN 100		
Code	Flange Pressure Rating		
G	PN 40		
E	PN 16 (DN 100 only)		
H	PN 64		
J	PN 100		
K	PN 160		
Code	Diaphragm Material ⁽³⁾	Extension/Gasket Surface Material	Flange/ Upper Housing Material
LA	316L SST	316L SST	316 SST
WW	316Ti SST (WNR 1.4571)	316Ti SST (WNR 1.4571)	316 SST (WNR 1.4571)
LB	<i>Hastelloy C-276</i>	<i>Hastelloy C-276</i>	316 SST
LM	<i>Hastelloy C-276</i>	316L SST	316 SST
LC	Tantalum	Tantalum	316 SST
LD	Tantalum	316L SST	316 SST
LR	Titanium GR.2	Titanium GR.2	316 SST
LJ	<i>Hastelloy B</i>	<i>Hastelloy B</i>	316 SST
LP	Nickel 201	Nickel 201	316 SST
L4	<i>Hastelloy C-22</i>	<i>Hastelloy C-22</i>	316 SST
LV	<i>Monel 400</i>	<i>Monel 400</i>	316 SST
LE	<i>Inconel 600</i>	<i>Inconel 600</i>	316 SST
Code	Extension Length ⁽⁴⁾		
2	50 mm		
4	100 mm		
6	150 mm		
8	200 mm		
0	0 mm		
1	25 mm		
3	75 mm		
5	125 mm		
7	175 mm		
9	225 mm		
Code	Extension Length (Amount to Add) ⁽⁴⁾		
0	Add 0 mm		
1	Add 2,5 mm		
2	Add 5 mm		
3	Add 7,5 mm		
4	Add 10 mm		
5	Add 12,5 mm		
6	Add 15 mm		
7	Add 17,5 mm		
9	Add 22,5 mm		
Code	Options (Multiple Selections)		
0	None		
6	Add 250 mm Extension Length		
7	Add 500 mm Extension Length		
V	<i>Teflon</i> Coated Diaphragm for non-stick purposes only (available with 316L SST and <i>Hastelloy C-276</i> diaphragm only)		
Z	Material Traceability per EN10204 DIN 3.1B (Requires Selection of Transmitter Code Q8)		

Product Data Sheet

00813-0201-4016, Rev GA

October 2004

Rosemount 1199

TABLE 9. EES and EFS Flanged Type: Extended Diaphragm Seal – DIN Ordering Information⁽¹⁾

2	Radial Capillary Connection - Available with 316L SST or 316Ti SST (WNR 1.4571) Diaphragm Material only
5	50 µm Diaphragm Thickness (available in 316L SST or <i>Hastelloy</i>)
8	150 µm Diaphragm Thickness - 316L SST or <i>Hastelloy</i> C-276 Diaphragm Material only
B	Extra Fill for Cold Temperature Applications
T	NACE MR-01-75

- (1) Shaded areas indicate special orders. Consult an Emerson Process Management representative for availability, performance effects, and lead time
- (2) Select for Tantalum and Titanium wetted parts only.
- (3) When ordering special diaphragm materials, the standard housing material is 316L SST unless noted otherwise. Consult an Emerson Process Management representative for use with spiral wound gaskets.
- (4) DIN extension lengths are specified in millimeters as offered. Additional lengths are available as special orders. Consult factory.

TABLE 10. EES and EFS Flanged Type: Extended Diaphragm Seal –ANSI Ordering Information⁽¹⁾

Code	Industry Standard		
A	ANSI/ASME B16.5 (American National Standards Institute/American Society of Mechanical Engineers)		
Code	Process Connection Style		
E	Flanged Type: Extended Diaphragm Seal		
Code	Gasket Surface Type		
FS	Serrated Finish		
ES	Smooth Finish ⁽²⁾		
Code	Process Connection Size		
G	2 in.		
7	3 in.		
9	4 in.		
Code	Flange Pressure Rating		
1	Class 150		
2	Class 300		
3	Class 400		
4	Class 600		
5	Class 900		
6	Class 1500		
7	Class 2500		
Code	Diaphragm Material ⁽³⁾	Extension/Gasket Surface Material	Flange/Upper Housing Material
LA	316L SST	316L SST	316 SST
LB	<i>Hastelloy</i> C-276	<i>Hastelloy</i> C-276	316 SST
LM	<i>Hastelloy</i> C-276	316L SST	316 SST
LC	Tantalum	Tantalum	316 SST
LD	Tantalum	316L SST	316 SST
LR	Titanium GR.2	Titanium GR.2	316 SST
LJ	<i>Hastelloy</i> B	<i>Hastelloy</i> B	316 SST
LP	Nickel 201	Nickel 201	316 SST
L4	<i>Hastelloy</i> C-22	<i>Hastelloy</i> C-22	316 SST
LV	<i>Monel</i> 400	<i>Monel</i> 400	316 SST
LE	<i>Inconel</i> 600	<i>Inconel</i> 600	316 SST
Code	Extension Length ⁽⁴⁾		
2	2 in.		
4	4 in.		
6	6 in.		
8	8 in.		
0	0 in.		
1	1 in.		
3	3 in.		
5	5 in.		
7	7 in.		
9	9 in.		

Rosemount 1199

TABLE 10. EES and EFS Flanged Type: Extended Diaphragm Seal –ANSI Ordering Information⁽¹⁾

Code	Extension Length (Amount to Add)
0	Add 0 in.
1	Add 1/8 in.
2	Add 1/4 in.
3	Add 3/8 in.
4	Add 1/2 in.
5	Add 5/8 in.
6	Add 3/4 in.
7	Add 7/8 in.
Code	Options (Multiple Selections)
0	None
V	<i>Teflon</i> Coated Diaphragm for non-stick purposes only (available with 316L SST and <i>Hastelloy</i> C-276 diaphragm only)
Z	Material Traceability per EN10204 DIN 3.1B (Requires Selection of Transmitter Code Q8)
2	Radial Capillary Connection - Available with 316L SST or 316Ti SST (WNR 1.4571) Diaphragms only
5	50 µm Diaphragm Thickness (available in 316L SST or <i>Hastelloy</i>)
6	Add 10-in. Extension Length
7	Add 20-in. Extension Length
8	150 µm Diaphragm Thickness - 316L or <i>Hastelloy</i> C-276 Diaphragm Material only
B	Extra Fill for Cold Temperature Applications
T	NACE MR-01-75

(1) Shaded areas indicate special orders. Consult an Emerson Process Management representative for availability, performance effects, and lead time.

(2) Select for Tantalum and Titanium wetted parts only.

(3) When ordering special diaphragm materials, the standard housing material is 316L SST unless noted otherwise. Consult an Emerson Process Management representative for use with spiral wound gaskets.

(4) ANSI extension lengths are in inches as offered. Additional lengths are available as special orders. Consult factory.

PFS Pancake (Cell) Type: Flush Diaphragm Seals

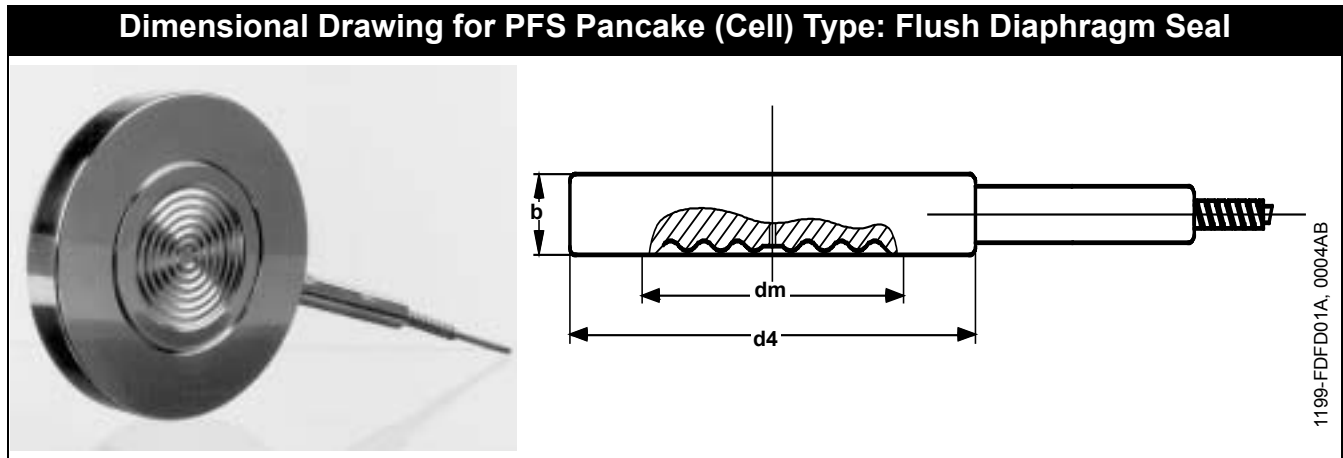

PFS Process Connection Dimensions

DIN 2501					ANSI/ASME B16.5				
DN	PN	Dimensions (mm)			DN	PN	Dimensions (mm)		
		dm	b	d4			dm	b	d4
25	16-400	25	22,9	68	1 in.	150-2500	25	22,9	51
50	16-400	57	22,9	102	1 1/2 in.	150-2500	40	22,9	73
80	16-400	89	22,9	138	2 in.	150-2500	57	22,9	92
100	16-400	89	22,9	158	3 in.	150-2500	89	22,9	127
					4 in.	150-2500	89	22,9	157

Dimensional Drawing for PFS Flushing Connection Ring

Flushing Ring Dimensions (mm)				
DN	d40	d4	b	G
50	59	102	20	1/4-18 NPT
80	91	138	20	1/4-18 NPT
2 in.	59	92	20	1/4-18 NPT
3 in.	91	127	20	1/4-18 NPT

TABLE 11. PFS Pancake (Cell) Type: Flush Diaphragm Seal – DIN Ordering Information⁽¹⁾

Code	Industry Standard	
D	DIN 2501 (Deutsches Institut für Normung)	
Code	Process Connection Style	
P	Pancake (Cell) Type: Flush Diaphragm Seal	
Code	Gasket Surface Type ⁽²⁾	
FS	DIN 2526 Form D	
Code	Process Connection Size	Diaphragm Diameter
G	DN 50	57 mm
J	DN 80	89 mm
D	DN 25	25 mm
F	DN 40	40 mm
K	DN 100	89 mm
Code	Pressure Rating	
0	Flanged not supplied. Seal rated to PN 16-400 or flange ratings	
Code	Diaphragm and Wetted Parts Material ⁽³⁾	Upper Housing Material
LA	316L SST	316 SST
LB	<i>Hastelloy C-276</i>	316 SST
LC	Tantalum	316 SST
WW	316Ti SST (WNR 1.4571)	316 SST (WNR 1.4571)
LE	<i>Inconel 600</i>	316 SST
LM	Titanium GR.2	316 SST (Only available with a smooth gasket surface)
LJ	<i>Hastelloy B</i>	316 SST
LP	Nickel 201	316 SST
L4	<i>Hastelloy C-22</i>	316 SST
LV	<i>Monel 400</i>	316 SST
LZ	Zirconium	316 SST
Code	Flushing Ring Material	
0	No Flushing Ring	
L	316L SST	
W	316Ti SST (WNR 1.4571)	
B	<i>Hastelloy C-276</i>	
Code	Flushing Options	
0	No Flushing Ring	
1	One 1/4-18 NPT Flushing Connection	
3	Two 1/4-18 NPT Flushing Connection	
7	One 1/2-14 NPT Flushing Connection	
9	Two 1/2-14 NPT Flushing Connection	
Code	Options (Multiple Selections)	
0	None	
V	<i>Teflon</i> Coated Diaphragm for non-stick purposes only (available with 316L SST and <i>Hastelloy C-276</i> diaphragm only)	
G	SST Plug(s) in Flushing Connection(s)	
H	SST Vent/Drain in Flushing Connection(s)	
Z	Material Traceability per EN10204 DIN 3.1B (Requires selection of transmitter code Q8)	
5	50 µm Diaphragm Thickness (available in 316L SST or <i>Hastelloy</i>)	
8	150 µm Diaphragm Thickness - 316L or <i>Hastelloy C-276</i> Diaphragm Material only ⁽⁴⁾	
B	Extra Fill for Cold Temperature Applications	
D	<i>Hastelloy</i> Plug(s) for Flushing Connection(s)	
1	Zone 0 Execution PTB Nr. III B/S 2415	
T	NACE MR-01-75	

(1) Shaded areas indicate special orders. Consult an Emerson Process Management representative for availability, performance effects, and lead time.

(2) Other gasket surfaces are possible; consult factory for coding and availability.

(3) When ordering special diaphragm materials, the standard housing material is 316L SST unless noted otherwise. Consult an Emerson Process Management representative for use with spiral wound gaskets.

(4) *Hastelloy C-276* is only available with a smooth gasket surface.

Product Data Sheet

00813-0201-4016, Rev GA

October 2004

Rosemount 1199

TABLE 12. PFS Pancake (Cell) Type: Flush Diaphragm Seal – ANSI/ASME Ordering Information⁽¹⁾

Code	Industry Standard	
A	ANSI/ASME B16.5 (American National Standards Institute/American Society of Mechanical Engineers)	
Code	Process Connection Style	
P	Pancake (Cell) Type: Flush Diaphragm Seal	
Code	Gasket Surface Type ⁽²⁾	
FS	Serrated Finish	
Code	Process Connection Size	Diaphragm Diameter
G	2 in.	57 mm
7	3 in.	89 mm
9	4 in.	89 mm
2	1 in.	25 mm
4	1 1/2 in.	40 mm
Code	Flange Pressure Rating	
0	Flange not supplied; seal rated to Class 150–2500 or flange rating	
Code	Diaphragm and Wetted Parts Material ⁽³⁾	Upper Housing Material
LA	316L SST	316 SST
LB	<i>Hastelloy C-276</i>	316 SST
LC	Tantalum	316 SST
WW	316Ti SST (WNR 1.4571)	316 SST (WNR 1.4571)
LE	<i>Inconel 600</i>	316 SST
LM	Titanium GR.2	316 SST (Only available with a smooth gasket surface)
LJ	<i>Hastelloy B</i>	316 SST
LP	Nickel 201	316 SST
L4	<i>Hastelloy C-22</i>	316 SST
LV	<i>Monel 400</i>	316 SST
LZ	Zirconium	316 SST
Code	Flushing Ring Material	
0	No Flushing Ring	
L	316L SST	
W	316Ti SST (WNR 1.4571)c	
B	<i>Hastelloy C-276</i>	
Code	Flushing Options	
0	No Flushing Ring	
1	One 1/4-18 NPT Flushing Connection	
3	Two 1/4-18 NPT Flushing Connection	
7	One 1/2-14 NPT Flushing Connection	
9	Two 1/2-14 NPT Flushing Connection	
Code	Options (Multiple Selections)	
0	None	
V	<i>Teflon</i> Coated Diaphragm for non-stick purposes only (available with 316L SST and <i>Hastelloy C-276</i> diaphragm only)	
G	SST Plug(s) in Flushing Connection(s)	
H	SST Vent/Drain in Flushing Connection(s)	
Z	Material Traceability per EN10204 DIN 3.1B (Requires selection of transmitter Code Q8)	
5	50 µm Diaphragm Thickness (available in 316L SST or <i>Hastelloy</i>)	
8	150 µm Diaphragm Thickness - 316L SST or <i>Hastelloy C-276</i> Diaphragm Material only ⁽⁴⁾	
B	Extra Fill for Cold Temperature Applications	
D	<i>Hastelloy</i> Plug(s) for Flushing Connection(s)	
1	Zone 0 Execution PTB Nr. III B/S 2415	
T	NACE MR-01-75	

(1) Shaded areas indicate special orders. Consult an Emerson Process Management representative for availability, performance effects, and lead time.

(2) Other gasket surfaces are possible; consult factory for coding and availability.

(3) When ordering special diaphragm materials, the standard housing material is 316L SST unless otherwise noted. Consult an Emerson Process Management representative for use with spiral wound gaskets.

(4) *Hastelloy C-276* is only available with a smooth gasket surface.

DES and DFS Pancake (Cell) Type: Extended Diaphragm Seals

Dimensional Drawing for DES and DFS Pancake Type: Extended Diaphragm Seals



1199-0006AB

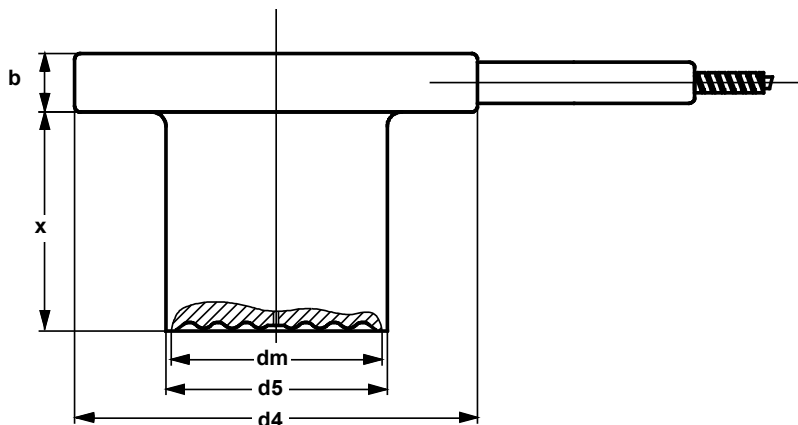

DIN Standard Extension Lengths x ⁽¹⁾	ANSI/ASME Standard Extension Lengths x ⁽¹⁾
50 mm	2 in.
100 mm	4 in.
150 mm	6 in.
200 mm	8 in.

(1) Other extension lengths are available upon request.

1199-EDB01A

DES and DFS Pancake (Cell) Process Connection Dimensions

		DIN 2501				ANSI/ASME B16.5					
DN	PN	Dimensions (mm)				DN	CL	Dimensions (mm)			
		dm	b	d4	d5			dm	b	d4	d5
50	16-400	40	20	102	48	2 in.	150-2500	40	20	92	48
80	16-400	72	20	138	76	3 in.	150-2500	72	20	127	76
100	16-400	89	20	162	96	4 in.	150-2500	89	20	157	96

TABLE 13. DES and DFS Pancake (Cell) Type: Extended Diaphragm Seal – DIN Ordering Information⁽¹⁾

Code		Industry Standard		
D		DIN 2501 (Deutsches Institut für Normung)		
Code		Process Connection Style		
D		Pancake (Cell) Type: Extended Diaphragm Seal		
Code		Gasket Surface Type		
FS		DIN 2526 Form D		
ES		DIN 2526 Form E ⁽²⁾		
Code		Process Connection Size		
G		DN 50		
J		DN 80		
K		DN 100		
Code		Pressure Rating		
0		Flange not supplied; seal rated to PN 16-400 or flange rating		
Code		Diaphragm Material⁽³⁾	Extension/Gasket Surface Material	
LA		316L SST	316L SST	
WW		316Ti SST (Wnr 1.4571)	316Ti SST (Wnr 1.4571)	
LB		<i>Hastelloy C-276</i>	<i>Hastelloy C-276</i>	
LC		Tantalum	Tantalum	
LE		<i>Inconel 600</i>	<i>Inconel 600</i>	
LR		Titanium GR.2	Titanium GR.2	
LJ		<i>Hastelloy B</i>	<i>Hastelloy B</i>	
LP		Nickel 201	Nickel 201	
L4		<i>Hastelloy C-22</i>	<i>Hastelloy C-22</i>	
LV		<i>Monel 400</i>	<i>Monel 400</i>	
LD		Tantalum	316L SST	
LM		<i>Hastelloy C-276</i>	316L SST	
Code		Extension Length⁽⁴⁾	Code	Extension Length
2		50 mm	0	0 mm
4		100 mm	1	25 mm
6		150 mm	3	75 mm
8		200 mm	5	125 mm
			7	175 mm
			9	225 mm
Code		Extension Length (Amount to Add)⁽⁴⁾	Code	Extension Length (Amount to Add)⁽⁴⁾
0		Add 0 mm	5	Add 12,5 mm
1		Add 2,5 mm	6	Add 15 mm
2		Add 5 mm	7	Add 17,5 mm
3		Add 7,5 mm	8	Add 20 mm
4		Add 10 mm	9	Add 22,5 mm
Code		Options (Multiple Selections)		
0		None		
V		<i>Teflon</i> Coated Diaphragm for non-stick purposes only (available with 316L SST and <i>Hastelloy C-276</i> diaphragm only)		
Z		Material Traceability per EN10204 DIN 3.1B (Requires selection of transmitter Code Q8)		
5		50 µm Diaphragm Thickness (available in 316L SST or <i>Hastelloy</i>)		
8		150 µm Diaphragm Thickness - 316L SST or <i>Hastelloy C-276</i> Diaphragm Material only		
6		Add 250 mm Extension Length		
7		Add 500 mm Extension Length		
B		Extra Fill for Cold Temperature Applications		
T		NACE MR-01-75		

(1) Shaded areas indicate special orders. Consult an Emerson Process Management representative for availability, performance effects, and lead time.

(2) Select for Tantalum wetted parts only.

(3) When ordering special diaphragm materials, the standard housing material is 316L SST unless noted otherwise. Consult an Emerson Process Management representative for use with spiral wound gaskets.

(4) DIN extension lengths are specified in millimeters, as offered. Other extension lengths are available as special offers on request.

TABLE 14. DES and DFS Pancake (Cell) Type: Extended Diaphragm Seal – ANSI/ASME Ordering Information⁽¹⁾

Code		Industry Standard					
A	ANSI/ASME B16.5 (American National Standards Institute/American Society of Mechanical Engineers)						
Code		Process Connection Style					
D	Pancake (Cell) Type: Extended Diaphragm Seal						
Code		Gasket Surface Type					
FS	Serrated Finish						
ES	Smooth Finish ⁽²⁾						
Code		Process Connection Size					
G	2 in.						
7	3 in.						
9	4 in.						
B	5 in.						
Code		Pressure Rating					
0	Flange not supplied; seal rated to Class 150–2500 or flange rating						
Code		Diaphragm Material ⁽³⁾	Extension/Gasket Surface Material				
LA	316L SST	316L SST					
WW	316Ti SST (WNR 1.4571)	316Ti SST (WNR 1.4571)					
LB	Hastelloy C-276	Hastelloy C-276					
LC	Tantalum	Tantalum					
LE	Inconel 600	Inconel 600					
LR	Titanium GR.2	Titanium GR.2					
LJ	Hastelloy B	Hastelloy B					
LP	Nickel 201	Nickel 201					
L4	Hastelloy C-22	Hastelloy C-22					
LV	Monel 400	Monel 400					
LD	Tantalum	316L SST					
LM	Hastelloy C-276	316L SST					
Code		Extension Length ⁽⁴⁾		Extension Length ⁽⁵⁾			
2	2 in.	0	0 in.				
4	4 in.	1	1 in.				
6	6 in.	3	3 in.				
8	8 in.	5	5 in.				
		7	7 in.				
		9	9 in.				
Code		Extension Length (Amount to Add)		Code		Extension Length (Amount to Add)	
0	Add 0 in	4	Add 1/2 in.	5	Add 5/8 in.		
1	Add 1/8 in	6	Add 3/4 in.				
2	Add 1/4 in.	7	Add 7/8 in.				
3	Add 3/8 in.						
Code		Options (Multiple Selections)					
0	None						
V	Teflon Coated Diaphragm for non-stick purposes only (available with 316L SST and Hastelloy C-276 diaphragm only)						
Z	Material Traceability per EN10204 DIN 3.1B (Requires selection of transmitter code Q8)						
5	50 µm Diaphragm Thickness (available in 316L SST or Hastelloy)						
8	150 µm Diaphragm Thickness - 316L or Hastelloy C-276 Diaphragm Material Only						
6	Add 10-in. Extension Length						
7	Add 20-in. Extension Length						
B	Extra Fill for Cold Temperature Applications						
T	NACE MR-01-75						

(1) Shaded areas indicate special orders. Consult an Emerson Process Management representative for availability, performance effects, and lead time.

(2) Select for Tantalum wetted parts only.

(3) When ordering special diaphragm materials, the standard housing material is 316L SST unless noted otherwise. Consult an Emerson Process Management representative for use with spiral wound gaskets.

(4) ANSI extension lengths are specified in inches as offered. Other extension lengths are available as special offers on request.

(5) ANSI extension lengths are specified in inches as offered. Other extension lengths are available as special offers on request.

HTS Threaded Type: Flush Diaphragm Seal

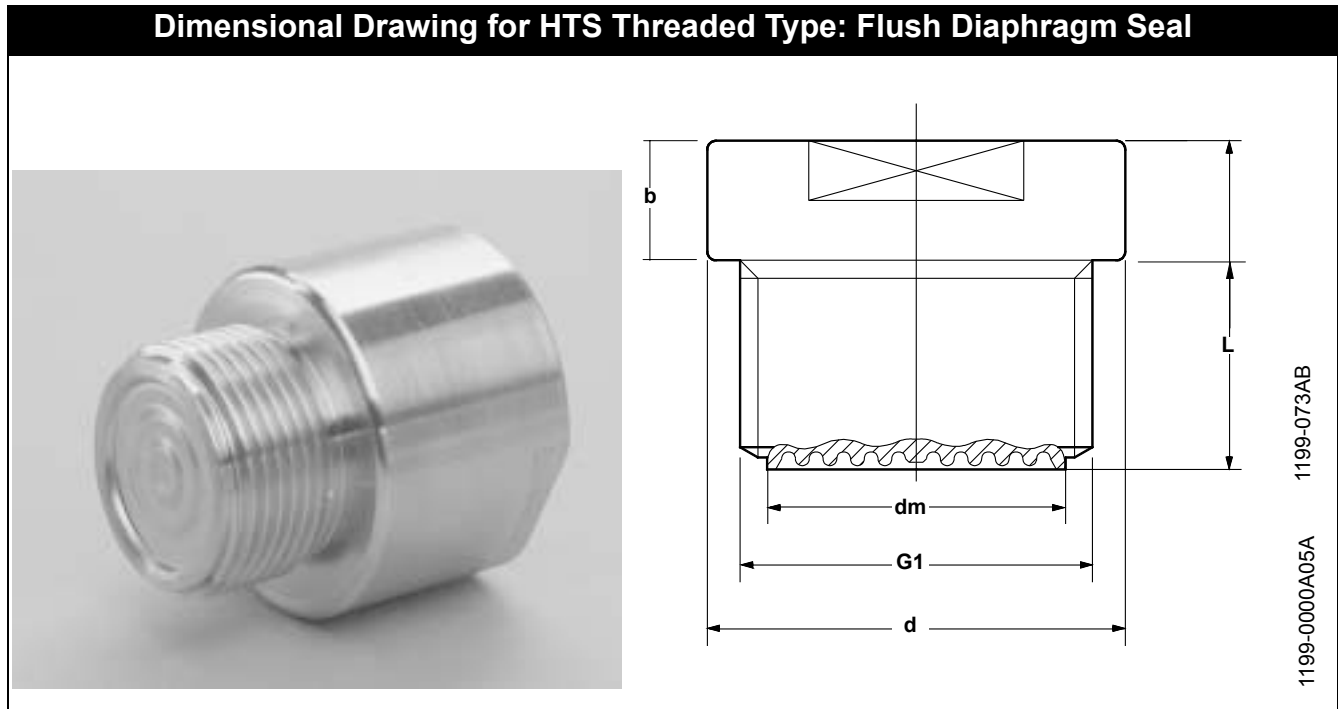

HTS Process Connection Dimensions

ISO 228/1 Parallel Thread						NPT: Tapered Thread					
G1	PN	Dimensions (mm)				G1	PN	Dimensions (mm)			
		dm	L	b	d			dm	L	b	d
1 in.	600	25	21	30	47	1 in.	600	25	23	30	47
1½ in.	600	32	30	30	60	1½ in.	600	32	32	30	60
2 in.	600	40	35	30	70	2 in.	600	40	37	30	70

Rosemount 1199

TABLE 15. HTS Threaded Type: Flush Diaphragm Seal — DIN Ordering Information⁽¹⁾

Code	Process Connection Style	
DHTS	Parallel Thread	
Code	Process Connection Size	Diaphragm Diameter
EA	G1 – 455 bar (6600 psi)	25 mm
GA	G1 ¹ / ₂ – 400 bar (5800 psi)	32 mm
JA	G2 – 280 bar (4000 psi)	40 mm
Code	Diaphragm and Wetted Parts Material	Housing Material
LA00	316L SST	316 SST
WW00	316Ti SST (WNR 1.4571)	316 SST (WNR 1.4571)
Code	Options (Multiple Selections)	
0	None	
Z	Material Traceability per EN10204 DIN 3.1B (Requires selection of transmitter Code Q8)	
5	50 µm Diaphragm Thickness (available in 316L SST or <i>Hastelloy C-276</i>)	
8	150 µm Diaphragm Thickness - 316L SST or <i>Hastelloy C-276</i> Diaphragm Material only	
B	Extra Fill for Cold Temperature Applications	
T	NACE MR-01-75	

(1) Consult an Emerson Process Management representative for use with low calibrated spans. Shaded areas indicate special orders, consult an Emerson Process Management representative for availability, performance effects, and lead time.

TABLE 16. HTS Threaded Type: Flush Diaphragm Seal —NPT Ordering Information⁽¹⁾

Code	Process Connection Style	
AHTS	Tapered Thread	
Code	Process Connection Size	Diaphragm Diameter
5A	1-11,5 NPT – 600 bar (8700 psi)	25 mm
7A	1½-11,5 NPT – 410 bar (6000 psi)	32 mm
9A	2-11,5 NPT – 280 bar (4000 psi)	40 mm
Code	Diaphragm and Wetted Parts Material	Housing Material
LA00	316L SST	316L SST
WW00	316Ti SST (WNR 1.4571)	316Ti SST (WNR 1.4571)
Code	Options (Multiple Selections)	
0	None	
Z	Material Traceability per EN10204 DIN 3.1B (Requires selection of transmitter Code Q8)	
5	50 µm Diaphragm Thickness (available in 316L SST or <i>Hastelloy C-276</i>)	
8	150 µm Diaphragm Thickness - 316L SST or <i>Hastelloy C-276</i> Diaphragm Material only	
B	Extra Fill for Cold Temperature Applications	
T	NACE MR-01-75	

(1) Consult an Emerson Process Management representative for use with low calibrated spans. Shaded areas indicate special orders, consult an Emerson Process Management representative for availability, performance effects, and lead time.

TFS Cell Type: In-Line Diaphragm Seal

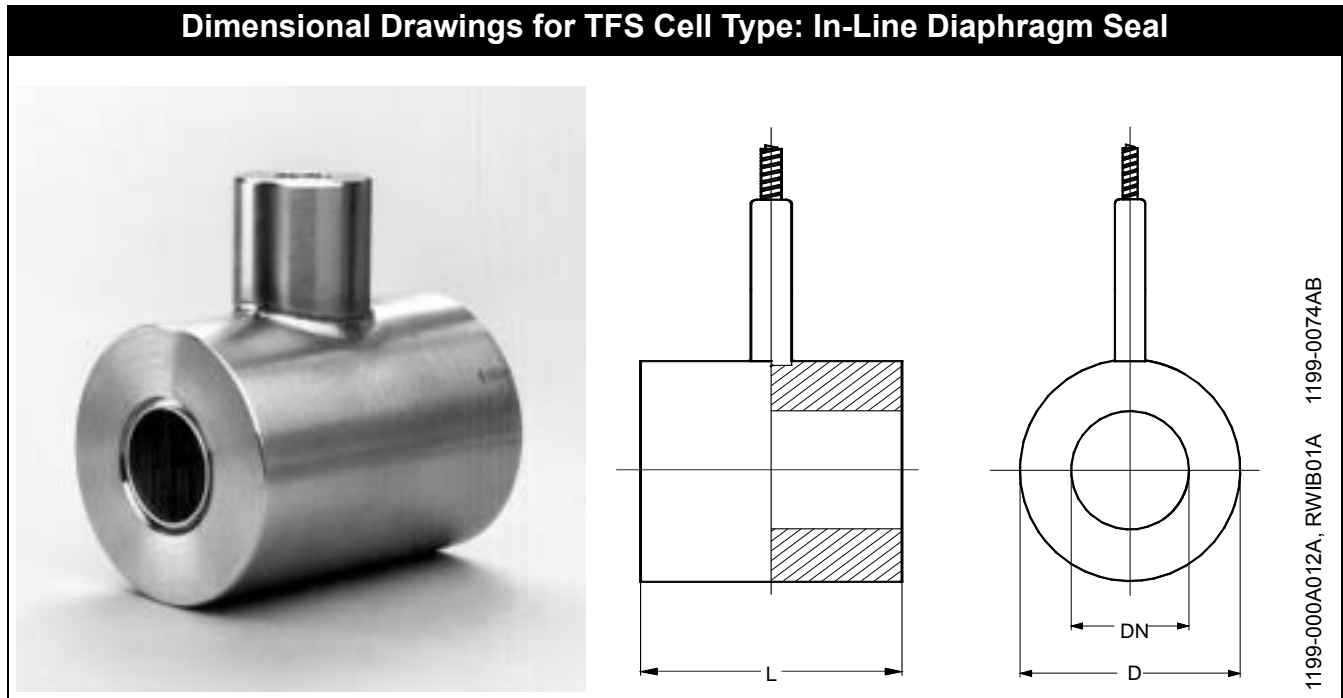

TFS Process Connection Dimensions

DIN 2501					ANSI/ASME B16.5				
Process Connection Size	PN	Dimensions (mm)			Process Connection Size	CL	Dimensions (mm)		
		DN	D	L			DN	D	L
25	16-400	27,7	68	90	1 in.	150-2500	27,7	51	90
40	16-400	41,0	88	90	1½ in.	150-2500	41,0	73	90
50	16-400	50	102	90	2 in.	150-2500	52,6	92	90
80	16-400	82	138	90	3 in.	150-2500	78,0	127	90
100	16-400	107	162	90	4 in.	150-2500	107	157	90

Rosemount 1199

TABLE 17. TFS Cell Type: In-Line Diaphragm Seal —DIN Ordering Information⁽¹⁾

Code	Industry Standard	
D	DIN 2501 (Deutsches Institut für Normung)	
Code	Process Connection Style	
T	Flanged Type: In-Line Diaphragm Seal	
Code	Gasket Surface	
FS	DIN 2526 Form D	
Code	Process Connection Size	
D	DN 25	
F	DN 40	
G	DN 50	
J	DN 80	
K	DN 100	
Code	Pressure Rating	
0	Flange not supplied; seal rated to PN 16-400 or flange rating	
Code	Diaphragm and Wetted Parts Material ⁽²⁾	Housing Material
LA00	316L SST	316 SST
LB00	<i>Hastelloy C-276</i>	316 SST
WW00	316Ti SST (W Nr 1.4571)	316 SST (W Nr 1.4571)
Code	Options (Multiple Selections)	
0	None	
Z	Material Traceability per EN10204 DIN 3.1B (Requires selection of transmitter Code Q8)	
T	NACE MR-01-75	

(1) Consult an Emerson Process Management representative for use with low calibrated spans. Shaded areas indicate special orders, consult an Emerson Process Management representative for availability, performance effects, and lead time.

(2) When ordering special diaphragm materials, the standard housing material is 316L SST unless noted otherwise.

TABLE 18. TFS Cell Type: In-Line Diaphragm Seal —ANSI/ASME Ordering Information⁽¹⁾

Code	Industry Standard	
A	ANSI/ASME B16.5 (American National Standards Institute/American Society of Mechanical Engineers)	
Code	Process Connection Style	
T	Flanged Type: In-Line Diaphragm Seal	
Code	Gasket Surface	
FS	Serrated Finish	
Code	Process Connection Size	
2	1 in.	
4	1½ in.	
G	2 in.	
7	3 in.	
9	4 in.	
Code	Pressure Rating	
0	Flange not supplied; seal rated to Class 2500 or flange rating	
Code	Diaphragm and Wetted Parts Material ⁽²⁾	Housing Material
LA00	316L SST	316L SST
LB00	<i>Hastelloy C-276</i>	316L SST
WW00	316Ti SST (W Nr 1.4571)	316Ti SST (W Nr 1.4571)
Code	Options (Multiple Selections)	
0	None	
Z	Material Traceability per EN10204 DIN 3.1B (Requires selection of transmitter Code Q8)	
T	NACE MR-01-75	

(1) Consult an Emerson Process Management representative for use with low calibrated spans. Shaded areas indicate special orders, consult an Emerson Process Management representative for availability, performance effects, and lead time.

(2) When ordering special diaphragm materials, the standard housing material is 316L SST unless noted otherwise.

Flow-Thru Flanged

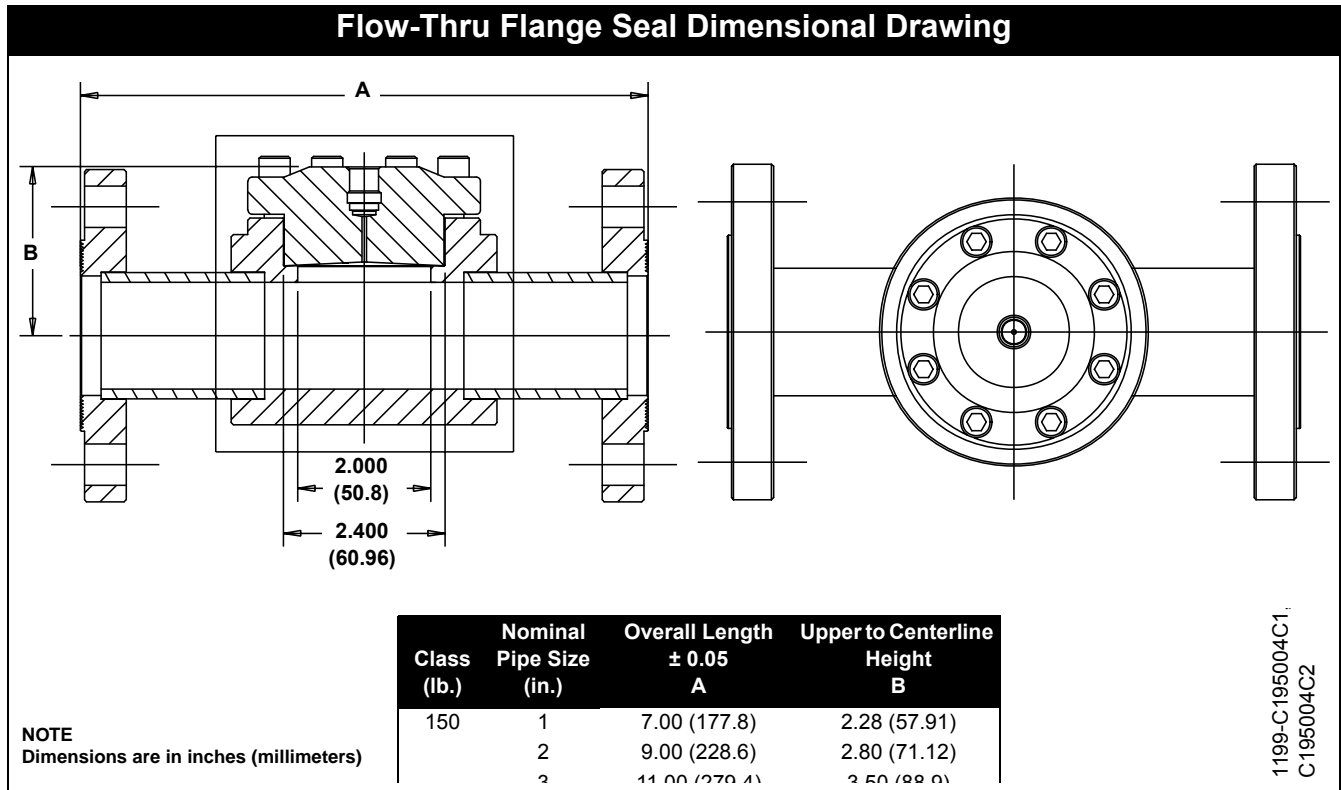

TABLE 19. Flow-Thru Flanged Seal Ordering Information

Code	Industry Standard			
A	ANSI/ASME B16.5 (American National Standards Institute/American Society of Mechanical Engineers)			
Code	Process Connection Style			
WFW	Flow-Thru Flanged			
Code	Process Connection Size ⁽¹⁾			
2	1 in.			
G	2 in.			
7	3 in.			
Code	Flange Pressure Rating ⁽¹⁾			
1	Class 150			
Code	Upper Housing	Diaphragm Material ⁽¹⁾		
LA	316 SST	316L SST		
Code	Lower Housing ⁽¹⁾			
L	316 SST			
Code	Pipe Schedule ⁽¹⁾	Maximum Working Pressure of Pipe		
		1 in.	2 in.	3 in.
N	40/40s	1500	1500	1500
Code	Options			
0	None			
3	304 SST Bolts			
J	Teflon O-ring (between Upper and Lower Housing)			
N	Grafoil Gasket (between Upper and Lower Housing)			
K	Gylon Gasket (between Upper and Lower Housing)			
B	Cold temperature application (ambient less than -20° C)			

⁽¹⁾ Consult factory for special process connection sizes, flange pressure ratings, diaphragm/lower housing materials, and pipe schedules.

Flow-Thru Socket and Butt Weld Seals

Flow-Thru Socket Weld

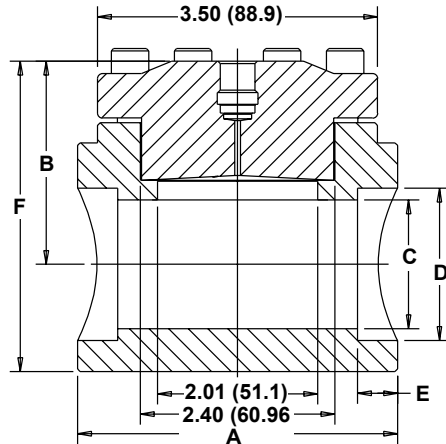
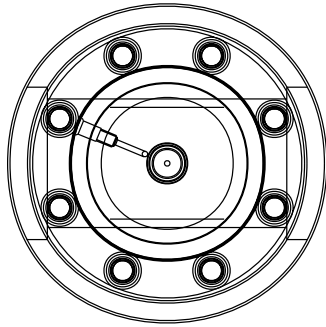

1199-C195007A, C195007B,
C195008A, C195008B

Code	Overall Length A	Upper to Centerline Height B	Bore Diameter C	Counter Bore Diameter D	Counter Bore Depth E	Overall Height F
A	3.50 (88.9)	2.18 (55.37)	0.82 (20.83)	1.06 (26.92)	0.40 (10.16)	3.09 (78.49)
2	3.50 (88.9)	2.28 (57.91)	1.05 (26.67)	1.32 (33.53)	0.40 (10.16)	3.33 (84.58)
4	4.00 (101.6)	2.56 (65.02)	1.61 (40.89)	1.91 (48.51)	0.50 (12.7)	3.90 (99.06)
G	4.00 (101.6)	2.80 (71.12)	2.07 (52.58)	2.38 (60.45)	0.50 (12.7)	4.37 (111.0)

Flow-Thru Butt Weld

1 in. Flow-Thru Butt Weld Seal

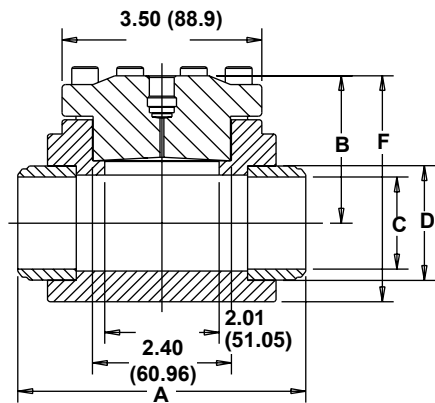
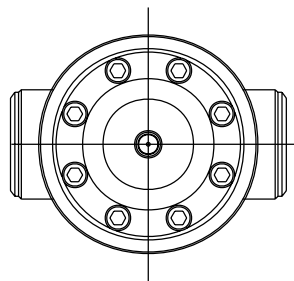

NOTE
Dimensions are in inches (millimeters)

Code	Overall Length A	Upper to Centerline Height B	Bore Diameter C	Counter Bore Diameter D	Overall Height F
A	4.25 (107.95)	2.17 (55.12)	0.82 (20.83)	1.05 (26.67)	3.13 (79.5)
2	4.25 (107.95)	2.29 (58.17)	1.05 (26.67)	1.32 (33.53)	3.39 (86.11)
4	5.00 (127.0)	2.57 (65.28)	1.61 (40.89)	1.90 (48.26)	3.95 (100.33)
G	5.00 (127.0)	2.77 (70.36)	2.07 (52.58)	2.38 (60.45)	4.38 (111.25)

TABLE 20. Flow-Thru Socket and Butt Weld Seals Ordering Information

Code	Industry Standard				
A	ANSI/ASME B16.5 (American National Standards Institute/American Society of Mechanical Engineers)				
Code	Process Connection Style				
WWW	Flow-Thru Socket Weld				
WBW	Flow-Thru Butt Weld				
Code	Process Connection Size ⁽¹⁾				
A	¾ in.				
2	1 in.				
4	1 ½ in.				
G	2 in.				
Code	Pressure Rating				
1	Not Applicable (See Pipe Schedule)				
Code	Upper Housing	Diaphragm Material ⁽¹⁾			
LA	316 SST	316L SST			
Code	Lower Housing ⁽¹⁾				
L	316 SST				
Code	Pipe Schedule ⁽¹⁾	Maximum Working Pressure of Pipe			
		¾ in.	1 in.	1 ½ in.	2 in.
N	40/40s	1500	1500	1500	1500
Code	Options				
0	None				
3	304 SST Bolts				
J	Teflon O-ring (between Upper and Lower Housing)				
N	Grafoil Gasket (between Upper and Lower Housing)				
K	Gylon Gasket (between Upper and Lower Housing)				
B	Cold Temperature application (ambient less than -20° C)				

(1) Consult factory for special process connection sizes, diaphragm/lower housing materials, and pipe schedules.

In-Line Flow-Thru Threaded Seal

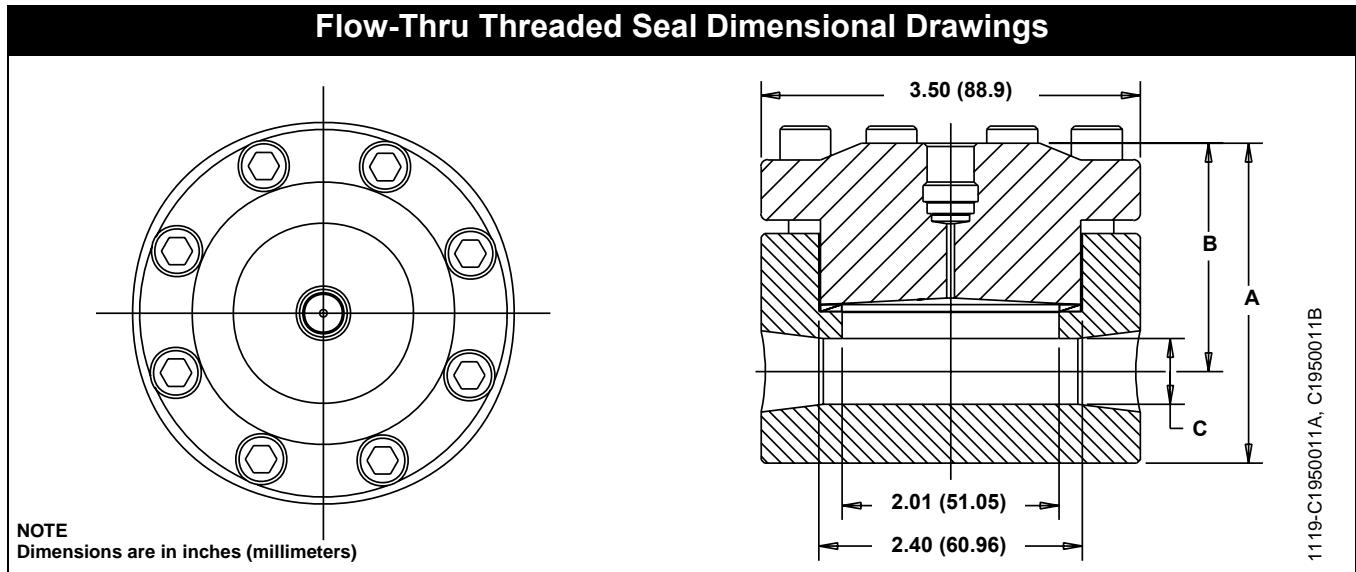

Code	Overall Length A	Upper to Centerline Height B	Bore Diameter C
1	2.62 (66.55)	1.97 (50.04)	0.44 (11.18)
3	2.91 (73.91)	2.12 (53.85)	0.72 (18.29)
4	3.13 (79.5)	2.22 (56.39)	0.92 (23.37)
5	3.38 (85.85)	2.34 (59.44)	1.15 (29.21)

TABLE 21. In-Line Flow-Thru Threaded Seal Ordering Information

Code	Industry Standard	
A	ANSI/ASME B16.5 (American National Standards Institute/American Society of Mechanical Engineers)	
Code	Process Connection Style	
WTW	In Line Flow-Thru Threaded	
Code	Process Connection Size	
1	¼ in. NPT	
3	½ in. NPT	
4	¾ in. NPT	
5	1 in. NPT	
Code	Pressure Rating	
1	Not Applicable (See Pipe Schedule)	
Code	Upper Housing	Diaphragm Material⁽¹⁾
LA	316 SST	316L SST
Code	Lower Housing⁽¹⁾	
L	316 SST	
Code	Pipe Schedule⁽¹⁾	Maximum Working of Pressure Pipe
N	40/40s	1,500 psi
Code	Options	
0	None	
3	304 SST Bolts	
J	Teflon O-ring (between Upper and Lower Housing)	
N	Grafoil Gasket (between Upper and Lower Housing)	
K	Gylon Gasket (between Upper and Lower Housing)	
B	Cold temperature application (ambient less than -20 °C)	

(1) Consult factory for special diaphragm materials, lower housing materials, and pipe schedules.

JES Extruder Flanged Type

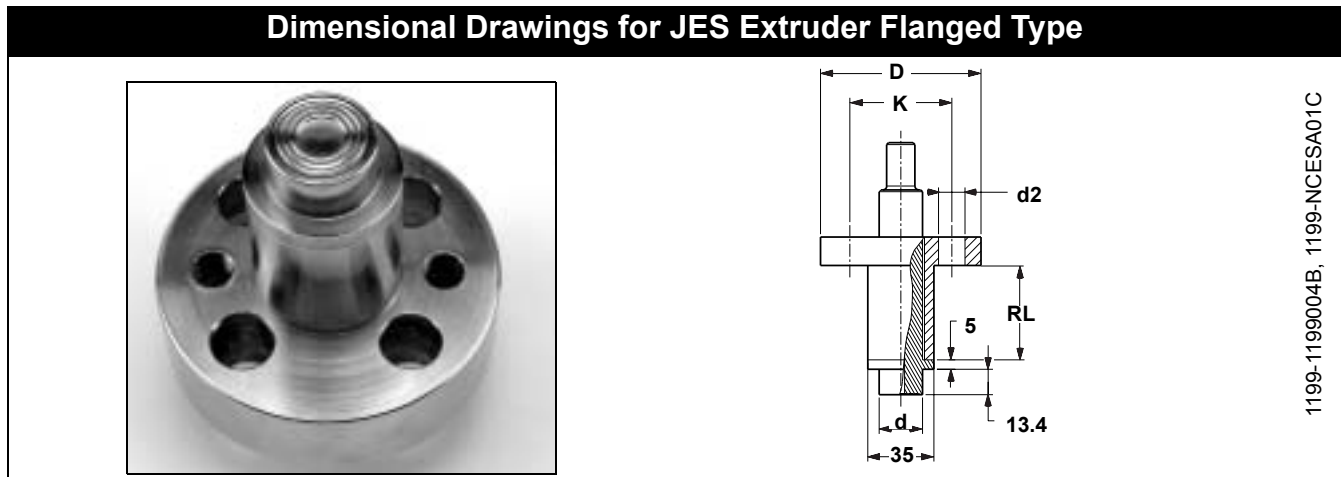

1199-1199004B, 1199-NCESA01C

JES Process Connection Dimensions (mm)						
PN	dM	D	K	d2	RL	Flange Thickness
400 bar	23	85	54	4x14	See Table 22	25 mm

TABLE 22. JES Extruder Flanged Type — Ordering Information⁽¹⁾

Code	Process Connection Style		
NJES	Plastics Extrusion Clamping Flange		
Code	Process Connection Size		
B	23 mm		
Code	Pressure Rating		
P ⁽²⁾	400 bar		
Code	Diaphragm and Wetted Parts Material	Upper Housing Material	
LA	316L SST	316 SST	
WW	316Ti SST (WNR 1.4571)	316 SST (WNR 1.4571)	
Code	Extension Length	Code	Extension Length
0	Add 0 mm	5	Add 50 mm
1	Add 10 mm	6	Add 60 mm
2	Add 20 mm	7	Add 70 mm
3	Add 30 mm	8	Add 80 mm
4	Add 40 mm	9	Add 90 mm
Code	Extension Length (Amount to Add)	Code	Extension Length (Amount to Add)
0	Add 0 mm	5	Add 5 mm
1	Add 1 mm	6	Add 6 mm
2	Add 2 mm	7	Add 7 mm
3	Add 3 mm	8	Add 8 mm
4	Add 4 mm	9	Add 9 mm
Code	Options (Multiple Selections)		
0	None		
5	50 μm Diaphragm Thickness		
6	Add 100 mm extension length		
7	Add 200 mm extension length		
Z	Material Traceability per EN10204 DIN 3.1B (Requires selection of transmitter Code Q8)		
T	NACE MR-01-75		

(1) Shaded areas indicate special orders. Consult an Emerson Process Management representative for availability, performance effects, and lead time.

(2) Minimum span is 60 bar.

Sanitary Diaphragm Seal Systems

VLS and VMS Sanitary In-Line Diaphragm Seals—
DIN 11851 or SMS Process Connections

Dimensional Drawing for VLS and VMS Sanitary In-Line Diaphragm Seals

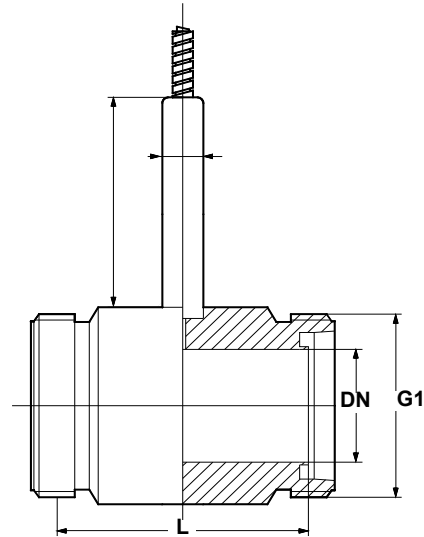

1199-RWIC01A, 1199-075AB

VLS and VMS Process Connection Dimensions⁽¹⁾

DIN 11851 ⁽¹⁾					SMS				
Process Connection Size	PN	Dimensions (mm)			Process Connection Size	PN	Dimensions (mm)		
		DN	G1	L			DN	G1	L
25	40	24,9	Rd52x1/6	90	25	40	24,9	Rd40x1/6	90
40	40	38,1	Rd65x1/6	90	38	40	38,1	Rd60x1/6	90
50	40	50	Rd78x1/6	90	51	40	50	Rd70x1/6	90
80	40	81,0	Rd110x1/4	90	76	40	76,0	Rd98x1/6	90
100	40	101	Rd130x1/4	90					

⁽¹⁾ RJT and IDF dimensions available upon request.

TABLE 23. VLS Sanitary In-Line Diaphragm Seal—DIN Ordering Information⁽¹⁾

Code	Industry Standard
S	Sanitary
Code	Process Connection Style ⁽²⁾
VLS	Sanitary In Line Seal per DIN 11851 (maximum working pressure: 40 bar)
Code	Process Connection Size
D0	DN 25
F0	DN 40
G0	DN 50
J0	DN 80
K0	DN 100
Code	Diaphragm Material
LA00	316L SST
WW00	316Ti SST (WNR 1.4571)
Code	Options (Multiple Selections)
0	None
6	Electrolytical polishing of diaphragm material
Z	Material Traceability per EN10204 DIN 3.1B (Requires selection of transmitter code Q8)

(1) Consult an Emerson Process Management representative for use with low calibrated spans. Shaded areas indicate special orders, consult an Emerson Process Management representative for availability, performance effects, and lead time.

(2) Other industry standards such as IDF and RJT available upon request.

TABLE 24. VMS Sanitary In-Line Diaphragm Seal—SMS Ordering Information⁽¹⁾

Code	Industry Standard
S	Sanitary
Code	Process Connection Style ⁽²⁾
VMS	Sanitary In Line Seal per SMS (maximum working pressure: 40 bar)
Code	Process Connection Size
20	DN 25
30	DN 38
50	DN 51
70	DN 76
Code	Diaphragm Material
LA00	316L SST
WW00	316Ti SST (WNR 1.4571)
Code	Options (Multiple Selections)
0	None
6	Electrolytical polishing of diaphragm material
Z	Material Traceability per EN10204 DIN 3.1B (Requires selection of transmitter code Q8)

(1) Consult an Emerson Process Management representative for use with low calibrated spans. Shaded areas indicate special orders, consult an Emerson Process Management representative for availability, performance effects, and lead time.

(2) Other industry standards such as IDF and RJT available upon request.

SLS, SMS, SFS and SRS Sanitary Seals: Dairy Process Connections—Female Thread

Dimension Drawing for SLS, SMS, SFS and SRS: Dairy Process Connections—Female Thread

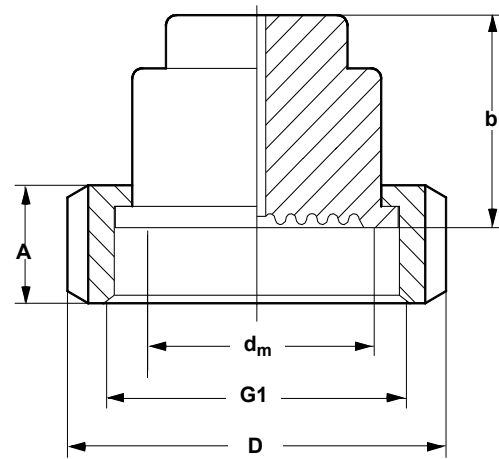

1199-0000B07A

SLS, SMS, SFS and SRS Process Connection Dimensions

STANDARD	Female Thread						
	DN	PN	A	b	d _m	G1	D
DIN 11851	25	40	21	45	25	Rd52×1/6	63
	32	40	21	40	32	Rd58×1/6	70
	40	40	21	45	40	Rd65×1/6	78
	50	40	22	46	57	Rd78×1/6	92
	65	40	25	47	59	Rd95×1/6	112
	80	40	29	47	76	Rd110×1/4	127
SMS	25	40	20	38	25	Rd40×1/6	51
	32	40	22	40	32	Rd48×1/6	60
	38	40	25	40	32	Rd60×1/6	74
	51	40	26	40	50	Rd70×1/6	84
	63,5	40	30	40	50	Rd85×1/6	100
	76	40	32	40	76	Rd98×1/6	114
IDF ⁽¹⁾							
RJT ⁽¹⁾							

(1) Contact factory for dimensions.

Product Data Sheet

00813-0201-4016, Rev GA

October 2004

Rosemount 1199

TABLE 25. SLS Sanitary Seals: Dairy Process Connection—**Female Thread** Ordering Information⁽¹⁾

Code	Industry Standard	
S	Sanitary	
Code	Process Connection Style	
SLS	Female Thread per DIN 11851	
Code	Process Connection Size	Pressure Rating ⁽²⁾
D0	DN 25	40 bar
F0	DN 40	40 bar
G0	DN 50	40 bar
J0	DN 80	40 bar
E0	DN 32	40 bar
H0	DN 65	40 bar
Code	Diaphragm Material	
LA00	316L SST	
WW00	316Ti SST (WNR 1.4571)	
Code	Options (Multiple Selections)	
0	None	
6	Electrolytical polishing of diaphragm material	
Z	Material Traceability per EN10204 DIN 3.1B (Requires selection of transmitter code Q8)	
2	Counterpiece (tank/pipe spud) and Gasket (ethylene propylene standard gasket material)	

(1) Shaded areas indicate special orders. Consult an Emerson Process Management representative for availability, performance effects, and lead time.

(2) Maximum working pressure is dependent on the pressure rating of the connection.

TABLE 26. SMS, SFS and SRS Sanitary Seals: Dairy Process Connection—**Female Thread** Ordering Information⁽¹⁾

Code	Industry Standard	
S	Sanitary	
Code	Process Connection Style	
SMS	Female Thread per SMS Standard	
SFS	Female Thread per IDF Standard	
SRS	Female Thread per RJT Standard	
Code	Process Connection Size	Pressure Rating ⁽²⁾
30	DN 38 (1½ in.)	40 bar
50	DN 51 (2 in.)	40 bar
20	DN 25	40 bar
60	DN 63.5	40 bar
70	DN 76	40 bar
Code	Diaphragm Material	
LA00	316L SST	
WW00	316Ti SST (WNR 1.4571)	
Code	Options (Multiple Selections)	
0	None	
6	Electrolytical polishing of diaphragm material	
Z	Material Traceability per EN10204 DIN 3.1B (Requires selection of transmitter code Q8)	
2	Counterpiece (tank/pipe spud) and Gasket (ethylene propylene standard gasket material)	

(1) Shaded areas indicate special orders. Consult an Emerson Process Management representative for availability, performance effects, and lead time.

(2) Maximum working pressure is dependent on the pressure rating of the connection.

MLS, MMS, MFS and MRS Sanitary Seal: Dairy Process Connections—Male Thread

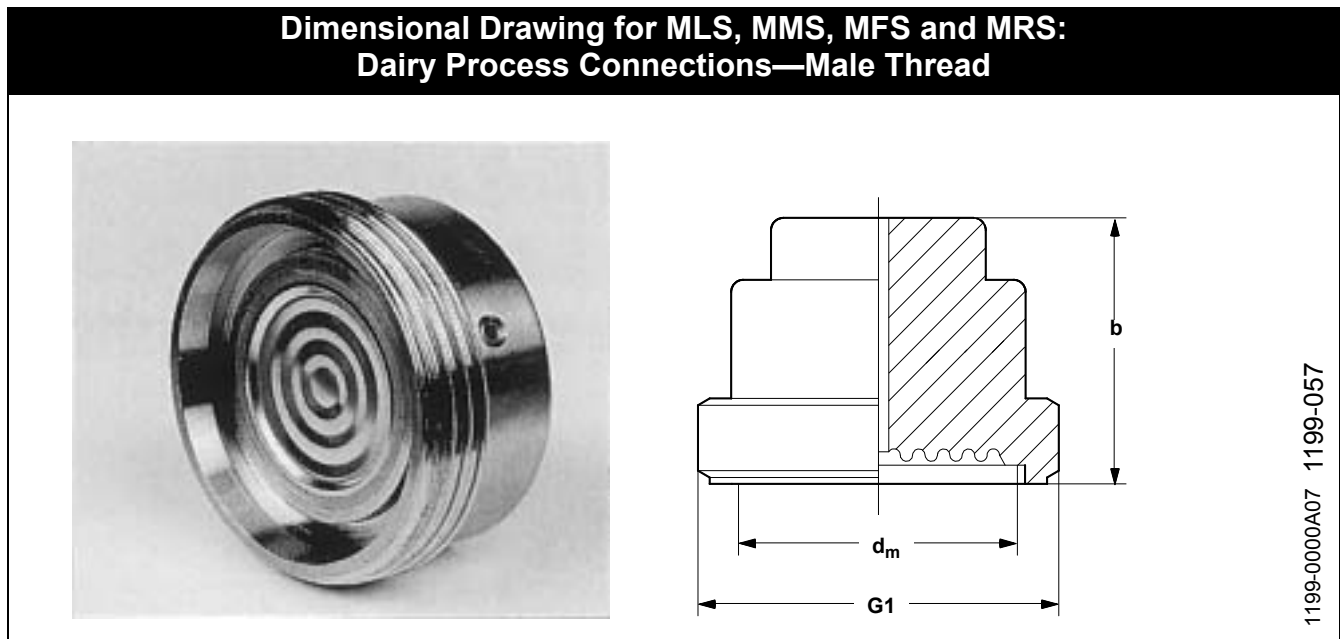

MLS, MMS, MFS and MRS Process Connection Dimensions					
STANDARD	DN	PN	Male Thread		
			DIMENSIONS (mm)		
			b	d _m	G1
DIN 11851	25	40	46	25	Rd52×1/6
	32	40	47	32	Rd58×1/6
	40	40	46	32	Rd65×1/6
	50	40	46	40	Rd78×1/6
	65	40	46	57	Rd95×1/6
	80	40	47	72	Rd110×1/4
SMS	25	40	47	25	Rd40×1/6
	32	40	47	32	Rd48×1/6
	38	40	47	32	Rd60×1/6
	51	40	47	40	Rd70×1/6
	63,5	40	47	57	Rd85×1/6
	76	40	47	72	Rd98×1/6
IDF ⁽¹⁾					
RJT ⁽¹⁾					

(1) Consult the factory for dimensions.

Product Data Sheet

00813-0201-4016, Rev GA

October 2004

Rosemount 1199

TABLE 27. MLS Sanitary Seal: Dairy Process Connections—**Male Thread** Ordering Information⁽¹⁾

Code	Industry Standard	
S	Sanitary	
Code	Process Connection Style	
MLS	Male Thread per DIN 11851	
Code	Process Connection Size	Pressure Rating ⁽²⁾
F0	DN 40	40 bar
G0	DN 50	40 bar
J0	DN 80	40 bar
D0	DN 25	40 bar
E0	DN 32	40 bar
H0	DN 65	40 bar
Code	Diaphragm Material	
LA00	316L SST	
WW00	316 Ti SST (WNR 1.4571)	
Code	Options (Multiple Selections)	
0	None	
6	Electrolytical polishing of diaphragm material	
Z	Material Traceability per EN10204 DIN 3.1B (Requires selection of transmitter code Q8)	
2	Counterpiece (tank/pipe spud) and gasket (standard gasket material ethylene propylene)	

(1) Shaded areas indicate special orders. Consult an Emerson Process Management representative for availability, performance effects, and lead time.

(2) Maximum working pressure is dependent on the pressure rating of the connection.

TABLE 28. MMS, MFS, and MRS Sanitary Seals: Dairy Process Connections—**Male Thread** Ordering Information⁽¹⁾

Code	Industry Standard	
S	Sanitary	
Code	Process Connection Style	
MMS	Male Thread per SMS Standard	
MFS	Male Thread per IDF Standard	
MRS	Male Thread per RJT Standard	
Code	Process Connection Size	Pressure Rating ⁽²⁾
30	DN 38 (1½ in.)	40 bar
50	DN 51 (2 in.)	40 bar
20	DN 25	40 bar
60	DN 63.5	40 bar
70	DN 76	40 bar
Code	Diaphragm Material and Wetted Parts	
LA00	316L SST	
WW00	316Ti SST (1.4571 WNR)	
Code	Options (Multiple Selections)	
0	None	
6	Electrolytical polishing of diaphragm material	
Z	Material Traceability per EN10204 DIN 3.1B (Requires selection of transmitter code Q8)	
2	Counterpiece (tank/pipe spud) and gasket (standard gasket material ethylene propylene)	

(1) Shaded areas indicate special orders. Consult an Emerson Process Management representative for availability, performance effects, and lead time.

(2) Maximum working pressure is dependent upon the pressure rating of the connection.

VCS Sanitary In-Line Diaphragm Seal—Tri-Clamp Process Connection

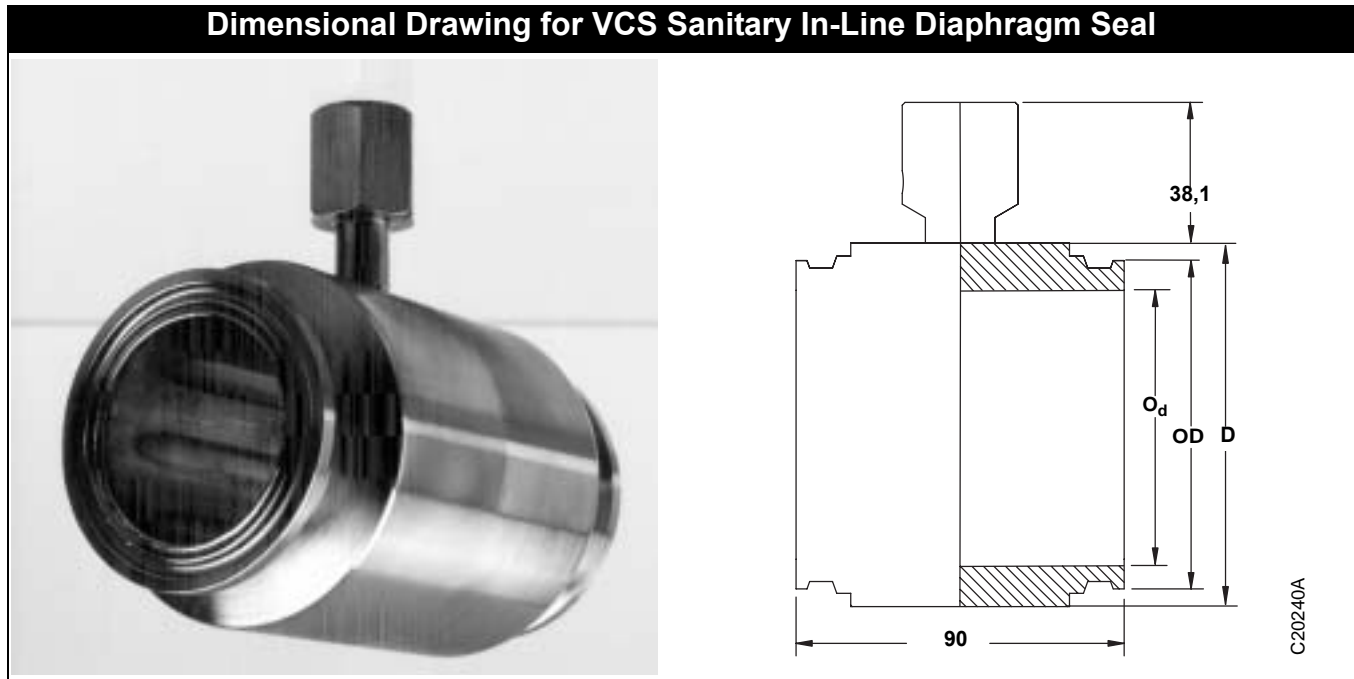

VCS Process Connection Dimensions

Max. Working Pressure	DN	Dimensions (mm)		
		O _d	OD	A
40 bar	1 in.	22,1	50,4	58
40 bar	1 1/2 in.	34,8	50,4	58
40 bar	2 in.	47,5	63,9	78,5
40 bar	2 1/2 in.	60,20	77,4	85,9
40 bar	3 in.	72,9	90,9	99
40 bar	4 in.	97	118,9	129

TABLE 29. VCS Sanitary In-Line Diaphragm Seal Ordering Information⁽¹⁾

Code	Industry Standard
S	Sanitary
Code	Process Connection Style
VCS ⁽²⁾	In Line <i>Tri-Clamp</i> Seal (Maximum Working Pressure: 40 bar)
Code⁽³⁾	Process Connection Size
20	1 in.
30	1½ in.
50	2 in.
70	3 in.
90	4 in.
Code	Diaphragm Material
LA00	316L SST
WW00	316Ti SST (WNR 1.4571)
	Options (Multiple Selections)
0	None
Z	Material Traceability per EN10204 DIN 3.1B (Requires selection of transmitter code Q8)

(1) Consult an Emerson Process Management representative for minimum calibrated spans. Shaded areas indicate special orders, consult an Emerson Process Management representative for availability, performance effects, and lead time.

(2) Gasket and clamp are furnished by the user. The maximum working pressure is dependent upon the pressure rating of the connection.

(3) DIN Tri-Clamp dimensions available on request.

SCS Sanitary *Tri-Clamp*® Diaphragm Seal

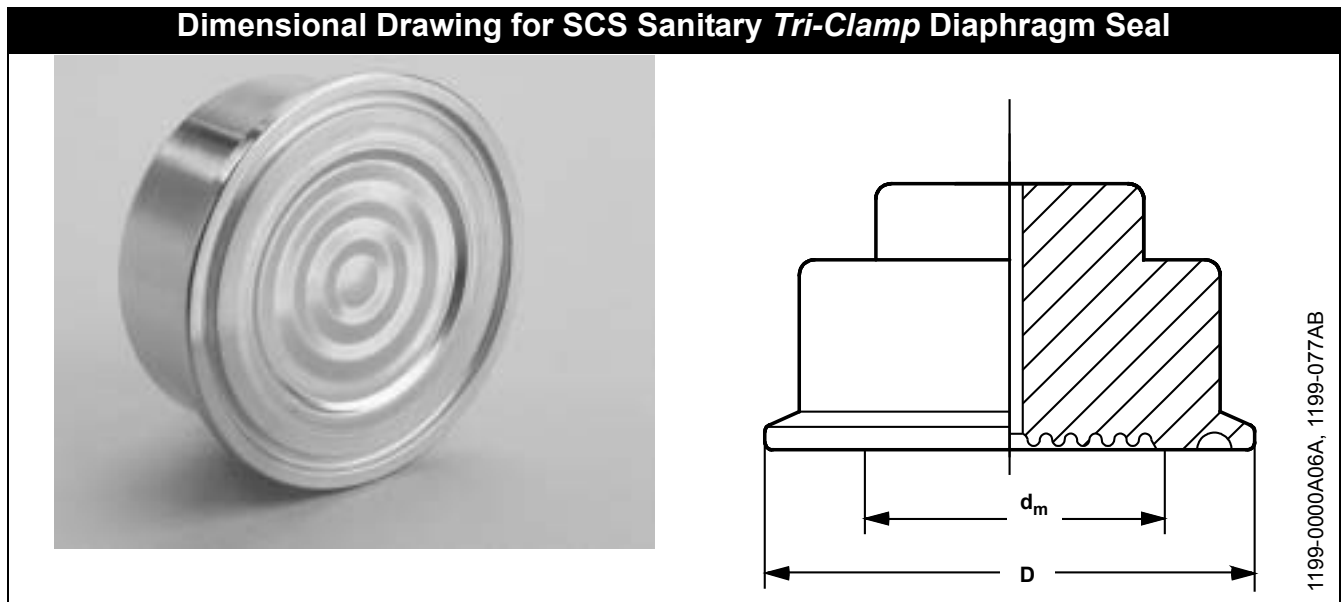

SCS Process Connection Dimensions			
DN	PN	Dimensions (mm)	
		d _M	D
1½ in.	40	32	50,4
2 in.	40	40	63,9
2½ in.	40	57	50,4
3 in.	40	72	90,9

TABLE 30. SCS Sanitary *Tri-Clamp* Diaphragm Seal Ordering Information⁽¹⁾

Code	Industry Standard
S	Sanitary
Code	Process Connection Style
SCS ⁽²⁾	<i>Tri-Clamp</i> Seal (maximum working pressure: 40 bar)
Code ⁽³⁾	Process Connection Size
30	1½ in.
50	2 in.
60	2½ in.
70	3 in.
Code	Diaphragm Material
LA00	316L SST
WW00	316Ti SST (WNr 1.4571)
Code	Options (Multiple Selections)
0	None
6	Electrolytical polishing of diaphragm material
Z	Material Traceability per EN10204 DIN 3.1B (Requires selection of transmitter code Q8)
B	Extra Fill for Cold Temperature Applications
2	Counterpiece (tank/pipe spud) and gasket (standard gasket material ethylene propylene)

(1) Consult an Emerson Process Management representative for minimum calibrated spans. Shaded areas indicate special orders, consult an Emerson Process Management representative for availability, performance effects, and lead time.

(2) Gasket and clamp furnished by user. The maximum working pressure is dependent upon the pressure rating of the connection.

(3) DIN *Tri-Clamp* sizes available on request.

EES Sanitary Tank Spud: Extended Diaphragm Seal

Dimensional Drawing for EES Sanitary Tank Spud Type: Extended Diaphragm Seal

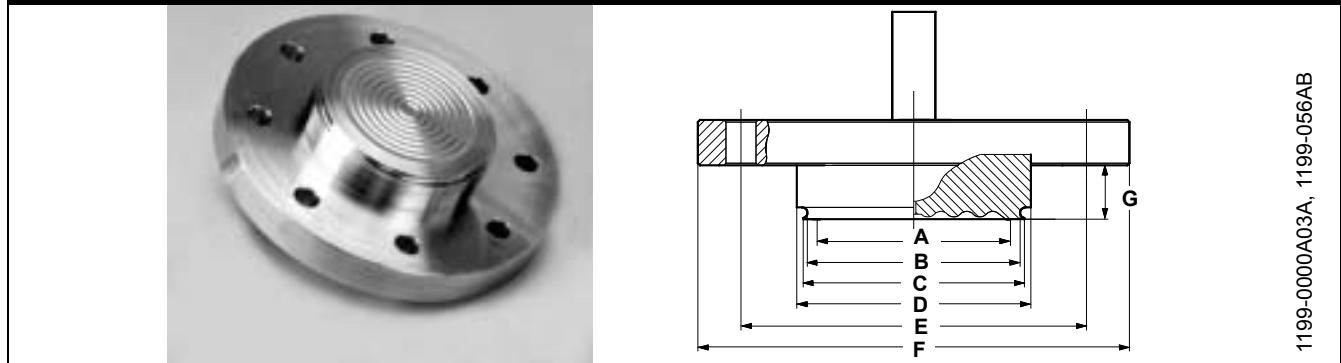

1199-0000A03A, 1199-056AB

		Dimensions (mm)							
DN	PN	A	B	C	D	E	F	G	
50	40	72	73	76	82.5	125	165	25	
80	40	89	98	102	108	160	200	25	

Flanged Type Tank Spud

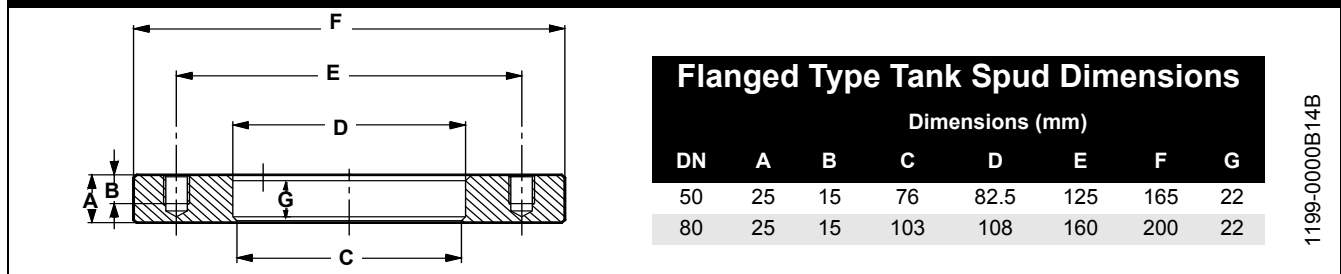

Flanged Type Tank Spud Dimensions							
Dimensions (mm)							
DN	A	B	C	D	E	F	G
50	25	15	76	82.5	125	165	22
80	25	15	103	108	160	200	22

1199-0000B14B

TABLE 31. EES Sanitary Tank Spud Type: Extended Diaphragm Seal Ordering Information⁽¹⁾

Code	Industry Standard
S	Sanitary
Code	Process Connection Style
EES	Flanged Tank Spud Seal Type: Extended Diaphragm Seal (Supplied with ethylene propylene gasket)
Code	Process Connection Size
JG	DN 80
GG	DN 50
Code	Flange Pressure Rating
JG	40 bar
GG	40 bar
Code	Diaphragm⁽²⁾
WW	316Ti SST (WNR 1.4571)
LA	316L SST
LB	Hastelloy C-276
Code	Extension Length⁽³⁾
10	25 mm
Code	Options (Multiple Selections)
0	None
1	Viton O-ring
2	Tank spud counterpiece to be welded on tank: includes Ethylene-Propylene O-ring, stainless steel bolts, and washers
Z	Material Traceability per EN10204 DIN 3.1B (Requires selection of transmitter code Q8)
5	50 μm Diaphragm Thickness (available in 316L SST or Hastelloy)
8	150 μm Diaphragm Thickness (316L SST or Hastelloy C-276 Diaphragm Material Only)
B	Extra Fill for Cold Temperature Applications
6	Electrolytical Polishing of Diaphragm Material
7	Blind Plug for Tank Spud Counterpiece

(1) Shaded areas indicate special orders. Consult an Emerson Process Management representative for availability, performance effects, and lead time.
 (2) When ordering optional diaphragm materials, the standard housing material is 316L SST unless noted otherwise.
 (3) Other extension lengths are available upon request.

Varivent Compatible Connection

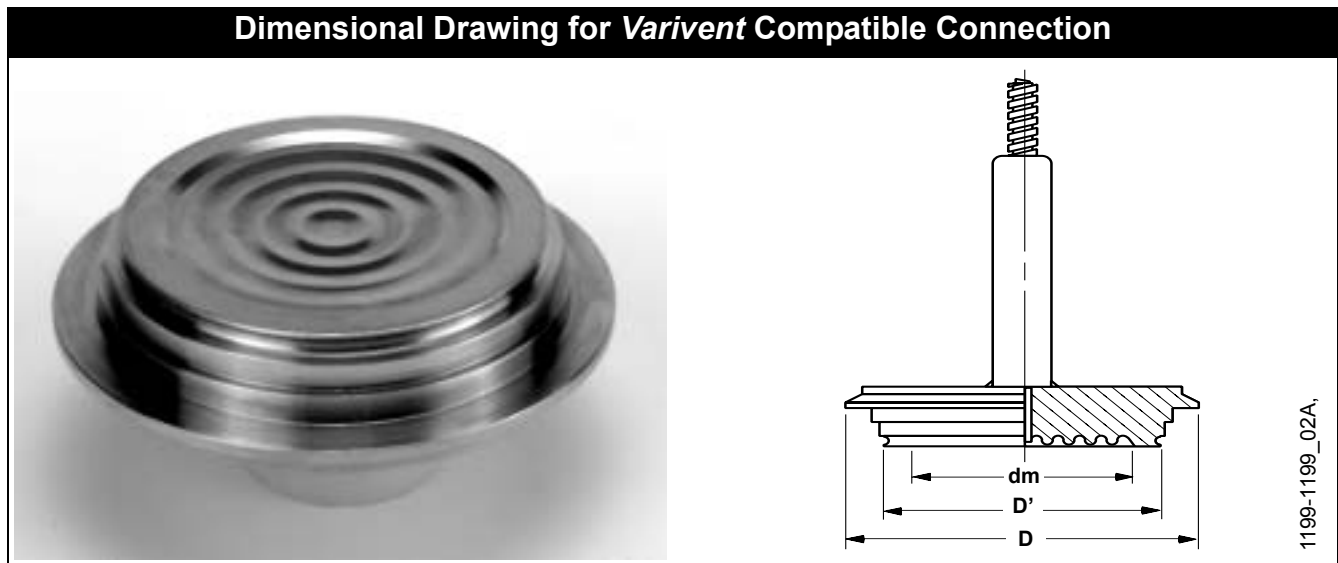

Varivent Compatible Process Connection Dimensions			
Dimensions (mm)			
dm	PN	D	D'
57 mm	40	84	68

TABLE 32. *Varivent* Compatible Sanitary Seal Ordering Information

Code	Industry Standard
S	Sanitary
Code	Process Connection Style
SVS	Off-line <i>Varivent</i> compatible (maximum working pressure: 40 bar)
Code	Process Connection Size
V0	<i>Varivent</i> compatible standard connection only
Code	Diaphragm Material
LA00	316L SST
WW00	316Ti SST (WNr 1.4571)
Code	Options (Multiple Selections)
0	None
6	Electrolytical polishing of diaphragm material
B	Extra Fill for Cold Temperature Applications
Z	Material Traceability per EN10204 DIN 3.1B (Requires selection of transmitter code Q8)

CHS Homogenizer Clamping Flange Type

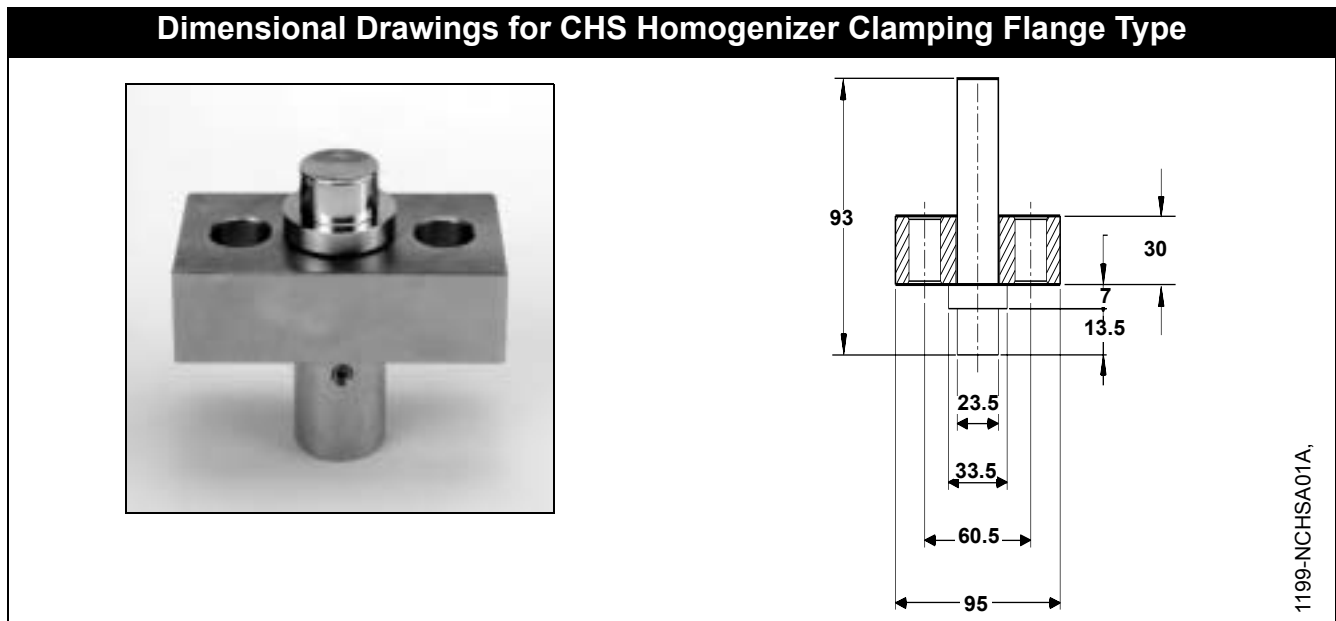

TABLE 33. CHS Homogenizer Clamping Flange Type—Ordering Information⁽¹⁾

Code	Process Connection Style
NCHS	Homogenizer Clamping Flange
Code	Process Connection Size
C	23,5 mm
Code ⁽²⁾	Pressure Rating
R	600 bar
Code	Diaphragm and Wetted Parts Material
LA00	316L SST
WW00	316Ti SST (Wnr 1.4571)
Code	Options (Multiple Selections)
0	None
5	50 μm Diaphragm Thickness (available in 316L SST or <i>Hastelloy</i>)
V	<i>Teflon</i> Coated Diaphragm for nonstick purposes only (available with 316L SST and <i>Hastelloy</i> C-276 diaphragm only)
B	Extra Fill for Cold Temperature Applications
Z	Material Traceability per EN10204 DIN 3.1B (Requires selection of transmitter code Q8)

(1) Shaded areas indicate special orders. Please consult an Emerson Process Management representative for availability, performance effects, and lead time.

(2) Minimum span is 60 bar.

General Information

WHAT IS A DIAPHRAGM SEAL SYSTEM?

A diaphragm seal system consists of a pressure transmitter, a diaphragm seal, a fill fluid, and either a direct-mount or capillary-style connection.

During operation, the flexible diaphragm and fill fluid separate the pressure sensitive element of the transmitter from the process medium. The capillary tubing or direct mount flange connects the diaphragm to the transmitter.

When process pressure is applied, the diaphragm transfers the measured pressure through the filled system and capillary tubing to the transmitter element. This transferred pressure displaces the sensing diaphragm in the pressure-sensitive element of the transmitter. The displacement is proportional to the process pressure and is electronically converted to an appropriate current, voltage, or digital *HART* output signal.

WHY USE DIAPHRAGM SEALS?

Seal systems provide a reliable process pressure measurement and prevent the process medium from contacting the transmitter diaphragm.

ADDITIONAL INFORMATION

This product data sheet provides information on Rosemount transmitter/diaphragm seal systems.

Rosemount 1199 diaphragm seals can be assembled to Rosemount 3051C, 1151, and 2088 differential, gage, and absolute pressure transmitters, and liquid level transmitters. For additional information, refer to the following product data sheets:

- Rosemount 1151 Alkaline Pressure Transmitters (document number 00813-0100-4360)
- Rosemount 3051 Pressure Transmitter (document number 00813-0100-4001)
- Rosemount 2088 Gage and Absolute Pressure Transmitter (document number 00813-0100-4690)

Transmitter/diaphragm seal systems should be considered when:

- The process **temperature** is outside of the normal operating ranges of the transmitter and cannot be brought into those limits with impulse piping.
- The process is **corrosive** and would require frequent transmitter replacement or unusual materials of construction.
- The process contains suspended **solids** or is **viscous** and may plug the impulse piping.
- The application requires the use of **sanitary connections**.
- There is a need for easier cleaning of the process from the connections to **avoid contamination** between batches.
- There is a need to **replace wet legs** to reduce maintenance on applications where the wet leg is not stable or often needs to be refilled.
- There is a need to make **density** or **interface measurements**.
- The process medium may **freeze** or **solidify** in the transmitter or impulse piping.

SPECIAL ORDERS

Many other special-order transmitter/diaphragm seal materials, configurations, and fill fluids are available that are not covered in this document. Contact an Emerson Process Management representative or consult the factory for special order information.

PERFORMANCE CONSIDERATIONS

Temperature Effects

Temperature effect errors occur when the fill fluid expands or contracts with fluctuations in the process or ambient temperature, thus causing a change in the internal pressure of the transmitter/seal system.

Two primary factors affect the temperature performance of a diaphragm seal system: the diaphragm stiffness and the characteristics of the fill fluid.

Rosemount 1199

Diaphragm Stiffness

Diaphragm stiffness is a critical parameter affecting temperature performance. As the fill fluid expands and contracts, due to temperature changes, a flexible diaphragm will exert less back pressure than a stiff diaphragm (for equal changes in fill volume). Back pressure causes a measurement error as it acts upon the sensing diaphragm of the transmitter. Therefore, the more flexible diaphragm seal can accommodate changes in fill volume and minimize errors resulting from temperature changes.

Diaphragm stiffness is affected by the diaphragm surface diameter, material of construction, thickness, and convolution pattern. Of these factors, the most significant is the diaphragm seal diameter. Each diaphragm has its own characteristic stiffness curve. Generally, smaller diameter diaphragms are more stiff than larger diameter diaphragms, and thus have stiffness curves that are less vertical. A more vertical stiffness curve helps to minimize the amount of pressure error that can occur when the fill fluid expands or contracts with temperature changes.

Figure 1 shows that large-diameter diaphragms, which are less stiff, have smaller errors caused by changes in the fill fluid volume. This is a result of a more vertical stiffness curve. The small-diameter diaphragms have a less vertical stiffness curve, resulting in larger errors with changes in temperature.

Fill Fluid

The expansion characteristics and the volume of the fill fluid affect seal performance.

All fill fluids expand and contract with changes in temperature. The coefficient of thermal expansion defines the amount of change and is represented in cubic centimeters of expansion per cubic centimeter of fluid per degree Celsius (cc/cc/°C). The amount of expansion varies between fill fluids, as shown in Figure 2. Selecting a fill fluid with a smaller coefficient of thermal expansion will help minimize temperature error. Table 1 on page 2 provides the coefficients of thermal expansion for all available fill fluids.

A larger volume of fill fluid increases the potential for volume expansion. By minimizing the capillary length and inside diameter, fill volumes can be kept as low as possible to reduce temperature error.

Time Response

Use of diaphragm seals increases the overall response time of transmitter/diaphragm seal systems. Time response varies with temperature, pressure, capillary length, inside diameter (ID), fill fluid, viscosity, and transmitter type.

Capillary ID: A smaller capillary inside diameter (ID) creates more restrictions and slows down the pressure transport. The larger capillary ID provides a faster response time.

Fill Fluid Viscosity: Viscosity of the fill fluid is a measure of its fluidity and is temperature dependent. Choosing a less viscous fill fluid enhances time response, especially when using longer capillaries in colder conditions.

FIGURE 1. Diaphragm Stiffness Curves

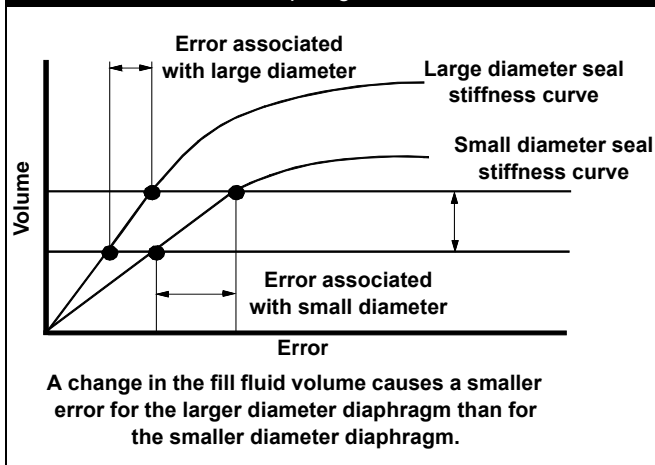
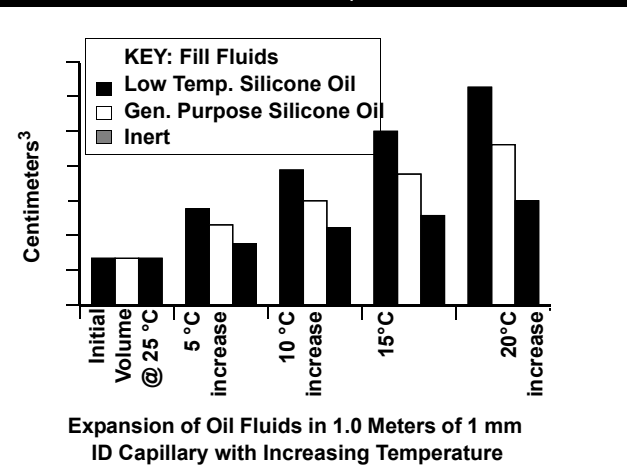

FIGURE 2. Effect of Fill Fluid Expansion on Fill Volume



Product Data Sheet

00813-0201-4016, Rev GA

October 2004

Rosemount 1199

Capillary Length: A longer capillary provides a greater distance for the pressure signal to travel, thus increasing the response time.

Applications with large tanks and slow changes in level, may not be hindered by a longer response time. Yet, a small, narrow tank may be subject to measurement difficulties if the response time is too slow. Applications that change rather quickly, such as flow, also require faster response times.

Summary

Adding seals to a transmitter can affect overall system performance. Selecting the most appropriate diaphragm seals, capillaries, and fill fluid can minimize these effects, maximize assembly performance, and still meet or exceed process demands.

Consider the following when selecting a diaphragm seal system:

- Use larger diameter diaphragms to minimize temperature effects.
- Keep capillary length as short as possible to reduce temperature effects and response time.
- Select larger ID capillaries to improve time response or select smaller ID capillaries to improve temperature performance.
- Select fill fluid that is the least viscous and has the smallest coefficient of thermal expansion while satisfying the most extreme process conditions.

Refer to Figure 3 for a summary of temperature effect and time response properties of various seal systems. In-line seal designs, diaphragm seal designs with diameters less than 50 mm and various other design configurations can result in significant temperature effect errors. Consult Instrument ToolKit or contact an Emerson Process Management representative for a detailed performance evaluation of a specific diaphragm seal system configuration.

DIRECT MOUNT SEAL CONNECTION TYPES

Rosemount 3051C, 1151, and 2088 transmitters with the Rosemount 1199 direct mount style seals are flange mounted directly to the vessel. They provide precise level and specific gravity measurements and are available in a wide variety of configurations.

The direct-mount connection is welded at the seal and the "L" bracket on Rosemount 3051C transmitters and at the seal and the transmitter flange for Rosemount 1151 and 2088 transmitters. Figure 4, 5, and 7 illustrate the various direct mount seal assembly configurations and weld locations.

FIGURE 3. Summary of Temperature Effect and Time Response with Various Seal, Capillary, and Fill Fluid Combinations

Temperature Response

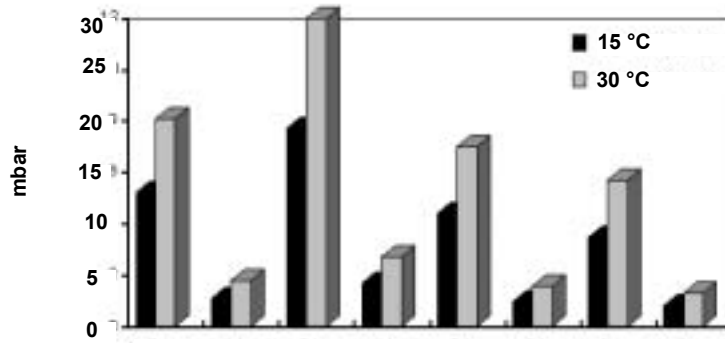

Diaphragm Diameter	50 mm	80 mm	50 mm	80 mm	50 mm
Fill Fluid	General Purpose	General Purpose	General Purpose	General Purpose	General Purpose
Capillary Length	5 m	5 m	5 m	5 m	3 m
Inside Diameter	1 mm	1 mm	2 mm	2 mm	1 mm

Time Response

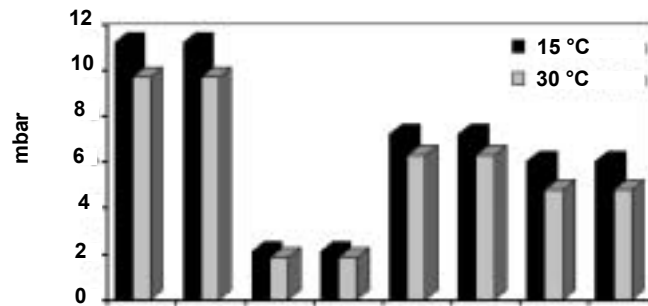

Diaphragm Diameter	50 mm	80 mm	50 mm	80 mm	50 mm	80 mm	50 mm	80 mm
Fill Fluid	General Purpose	General Purpose	General Purpose	General Purpose	General Purpose	General Purpose	Inert	Inert
Capillary Length	5 m	5 m	5 m	5 m	3 m	3 m	3 m	3 m
Inside Diameter	1 mm	1 mm	2 mm	2 mm	1 mm	1 mm	1 mm	1 mm

Direct Mount Option Code Index

FIGURE 4. Rosemount 3051 Direct Mount Connection Type

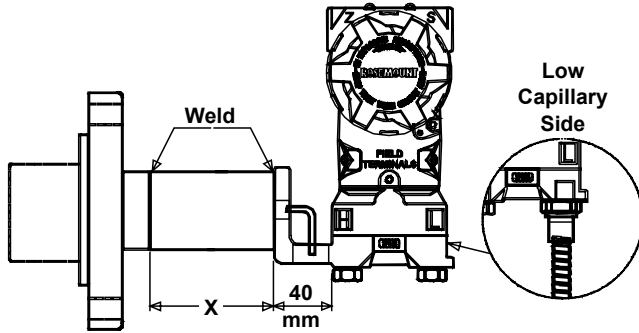

FIGURE 5. Rosemount 3051

Rosemount 3051 Direct-Mount Connections

Connection	X = 50 mm	X = 100 mm
One Seal	B3	D3
Two Seals	B4	D4
One Seal All-Welded	B7	D7
Two Seals All-Welded	B6	D6

Rosemount 3051T (option code S1)	Rosemount 1151 (option code S1 or S2)	Rosemount 2088 (option code S1)
Direct Mount Connection One Seal Connection = Option Code 95 (L = 25 mm) One Seal Connection = Option Code A5 (L = 50 mm)	Direct Mount Connection One or Two Seal Connections = option code 92	Direct Mount Connection One Seal Connection = Option Code 95 (L = 25 mm) One Seal Connection = Option Code A5 (L = 50 mm)

FIGURE 6. Rosemount 3051T Direct Mount Connection Type

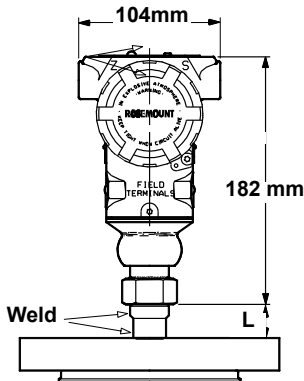

FIGURE 7. Rosemount 1151 Direct Mount Connection Type

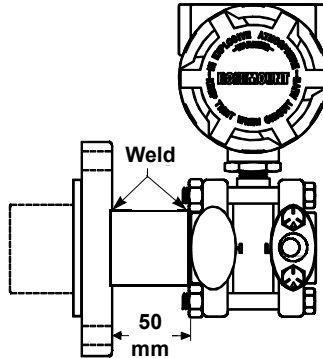
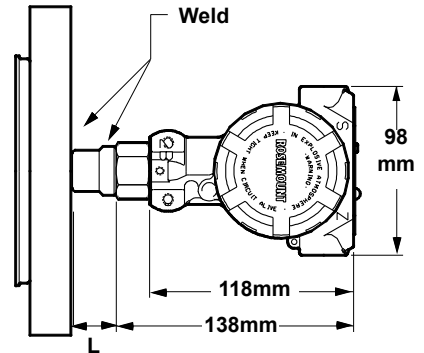

FIGURE 8. Rosemount 2088 Direct Mount Connection Type



Rosemount 1199

VACUUM APPLICATIONS

There are three parameters to consider when selecting a transmitter/seal system for vacuum applications: fill fluid compatibility, configuration, and installation.

TABLE 34.

Fill Fluid Compatibility	Configuration	Installation
<p>The fill fluid must be able to withstand the highest temperature and lowest process pressure conditions under which the transmitter will be operating. Therefore, the fill fluid must have a vapor pressure that is compatible with the most extreme process conditions. (Be sure to consider temperature and pressure conditions during start-up and system cleaning operations).</p> <p>Temperature limits of fill fluids, as shown in Table 6 on page 3, are stated for positive and vacuum pressure conditions. Figure 9 provides the vapor pressure curves for general purpose, high temperature, and sanitary fill fluids.</p>	<p>Transmitter Connections</p> <p>For moderate to high vacuum applications, the Rosemount 1151 transmitter is available with a vacuum resistant gasket, to ensure extra reliability.</p> <p>For full vacuum applications, the Rosemount 3051C All Welded System is available. This transmitter/seal system welds the following four connection points, as shown in Figure 9:</p> <ol style="list-style-type: none"> 5. Capillary-to-transmitter flange connection 6. Module-to-capillary connection 7. Transmitter fill screw 8. 316 SST bolts on the module-to-flange connection 	<p>For vacuum applications, to ensure positive pressure at the transmitter, mount the transmitter so that it is level with, or below the lowest tap.</p> <p>Under the following conditions, the transmitter fill fluid may start to vaporize, at which point, the transmitter will cease to make appropriate readings:</p> <ul style="list-style-type: none"> • The transmitter is mounted above the lower tap (causing a negative head effect) • The process pressure is less than the head pressure exerted by the fill fluid. • This puts the transmitter fill fluid under a vacuum, thereby degrading the maximum operating temperature <p>If the operating temperature and vacuum pressure exceed the vapor pressure point of the transmitter fill fluid, the fill fluid is likely to vaporize.</p>

FIGURE 9. Fill Fluid Vapor Pressure Curves and Rosemount 3051C All-Welded System

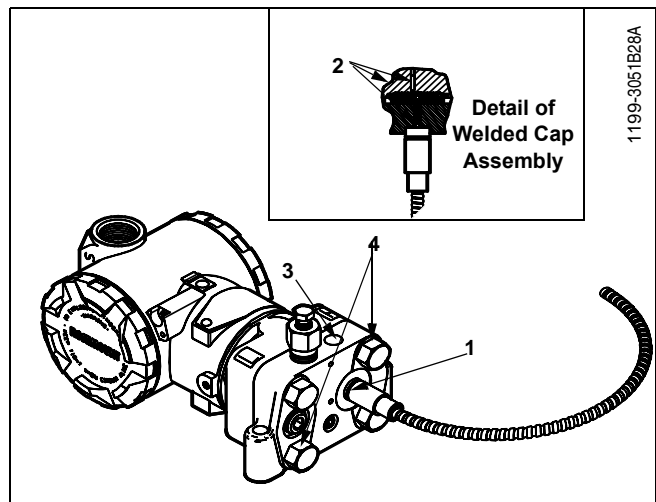
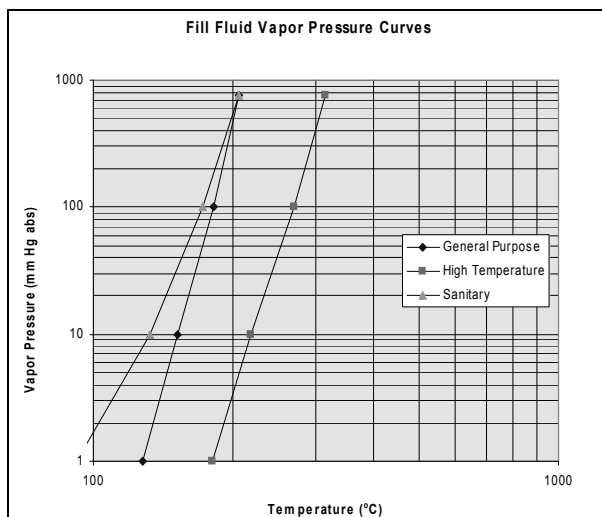

1199-3051B28A

*Rosemount, Tri-Clamp, and the Rosemount logotype are registered trademarks of Rosemount Inc.
Inconel, Monel is a registered trademark of International Nickel Co.
Hastelloy is a registered trademark of Haynes International.
HART is a registered trademark of the HART Communication Foundation.
Teflon is a registered trademark of E.I. du Pont de Nemours & Co.
Varivent is a registered trademark of Tuchenhagen Nederland B.V.
All other marks are the property of their respective owners.*

Emerson Process Management

Rosemount Inc.

8200 Market Boulevard
Chanhassen, MN 55317 USA
T (U.S) 1-800-999-9307
T (International) (952) 906-8888
F (952) 949-7001

www.rosemount.com



Emerson Process Management GmbH & Co. OHG

Argelsrieder Feld 3
82234 Wessling
Germany
T 49 (8153) 9390
F 49 (8153) 939172

Emerson Process Management Asia Pacific Private Limited

1 Pandan Crescent
Singapore 128461
T (65) 6777 8211
F (65) 6777 0947/65 6777 0743