

Product Data Sheet

PDS 103-700.A01

September, 2005

Model 700 Process Gas Chromatograph

The Model 700 Process Gas Chromatograph is an advanced combination of technology and rugged instrumentation that helps make the most of existing plant manpower. Today's trend toward downsizing means instrumentation technicians have more to do in less time. Instrumentation has to be more reliable and easier to use than ever before. Emerson's Rosemount Analytical Process Gas Chromatographs are your best choice; we've built our reputation on equipment reliability and long-term performance with ease of use.

FEATURES

- Newest Rosemount Analytical Process Gas Chromatograph offering from Emerson
- Fully compatible with modern Ethernet networks and DCS communication
- Designed for field-mounting without the need for expensive analyzer shelters and without sacrificing analytical power
- Diaphragm-based chromatograph valves available in 6-port and 10-port versions
- Thermal Conductivity Detector (TCD) sensitive down to very low parts-per-million levels
- Flame Ionization Detector (FID) sensitive to parts-per-billion levels
- Every Model 700 is rigorously tested in an environmental chamber between 0° to 130°F for 24 hours minimum
- Last chromatogram for each sample and calibration stream stored in Process Gas Chromatograph
- Archives up to 254 item averages, more than 3 months of standard runs and calculations



APPLICATIONS

The Model 700 is designed for a variety of refining, petrochemical, food and beverage, pharmaceutical, power and environmental applications where selected components in gaseous or liquid streams must be precisely monitored on a continuous basis.

Refineries

- Catalytic reformer
- Isomerization unit
- Aromatics unit

Petrochemical

- Ethylene plants
- Polymer plants
- Acrylonitrile plants

Gas Processing

- NGL and LNG plants
- Cryogenic gas plants

Power Generation

- Power generation plants
- Gas turbine control

Environmental Monitoring

- Ambient air monitoring
- HR-VOCs in flares and cooling towers

The Rosemount Analytical Process Gas Chromatograph Difference

- Broad application scope with single- or dual- detector capability
- Extreme ambient temperature operation minimizes installation and utility requirements
- High-sensitivity thermal conductivity detectors can often replace the need for more complex detectors
- Easy-to-use MON2000 software for advanced diagnostics and simplified troubleshooting; simply the best in the industry
- Rosemount Analytical diaphragm valves offer a lifetime warranty

ROSEMOUNT[®]
Analytical

Visit our website at www.rainhome.com
On-line ordering available.



EMERSON[™]
Process Management

Gas Chromatograph Valves

The chromatograph valves used in Rosemount Analytical Process Gas Chromatographs are unique to the on-line Gas Chromatograph market. Using a design originally developed by NASA, the valve offers greatly extended operating life. Emerson Process Management is currently the only on-line Gas Chromatograph supplier to offer a lifetime warranty on their Rosemount Analytical chromatograph valves!

- Choice 6-port and 10-port, diaphragm valve
- Simple mechanical design
- Sample does not come in contact with internal moving parts
- More than 5 million operations per valve
- Lifetime warranty
- Rotary and Liquid Injection Valves also available for special applications

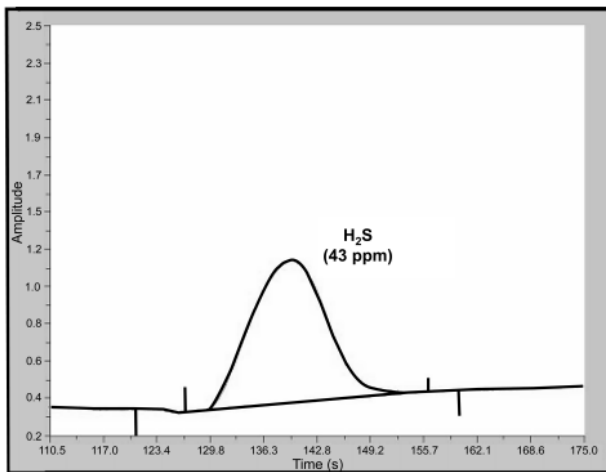
The reason for the exceptional durability of the valve is its unique double-diaphragm actuation. The double-diaphragm design eliminates the need for springs, o-rings and lubrication. Flow paths in the valve are arranged so that internal moving parts never contact the sample flow. As a result, abrasive mechanical wear on machined valve surfaces is eliminated. The valves are rated for over 5 million operations before repair (approximately 3-5 years of usage). And then, repair is typically simply changing the diaphragms in the valve.



For many part-per-million applications, a simple easy-to-maintain TCD detector can be used rather than a more complicated FID or FPD due to the superior sensitivity of the Rosemount Analytical TCD design.

Most importantly, the Rosemount Analytical valve offers excellent performance. The valve is available in both 6-port and 10-port versions to handle both simple and complex column valve arrangements. Minimal internal movement of the components in the valve – roughly 1/1000th of an inch – contributes to rapid actuation of the valve, which can be important for applications using micro-packed and capillary columns.



The diaphragm valve used in the Model 700 is available in both 6-port and 10-port versions for maximum application flexibility.

Detectors

The Model 700 Process Gas Chromatograph has the selection of detectors to handle the wide range of analytical demands found in typical process applications. Whether the components of interest are in the percent range or down to the parts-per-million range, precise and reliable measurement is possible.

- TCD detector is sensitive down to 3 ppm
- Micro-FID detector is sensitive down to the parts-per-billion level
- Dual TCD / TCD or TCD / FID configurations possible
- Flame Photometric Detector (FPD) Module also available

The thermistor TCD is the detector of choice for most applications due to its universal response to all compounds. Emerson's Rosemount Analytical TCD is able to go well beyond the normal measuring ranges seen in other designs by being able to do many applications with low parts-per-million measurement requirements. This greatly simplifies the Process Gas Chromatograph design when a simple and rugged TCD can be used rather than an FID.

For measurement of most organic compounds in the low ppm or even ppb ranges, the Flame Ionization Detector (FID) is an option available for the Model 700. Its micro design is perfect for the transmitter-style enclosure of the Model 700 without sacrificing analytical power. An FPD Module is available for trace Sulfur measurement (ppb-level) applications.

Heat Sink Oven

The Heat Sink Oven design of the Model 700 brings stable and precise measurement to the field without the need for expensive analyzer shelters.

- Airless oven analytical kiosk with oven temperatures up to 100°C
- Up to 3 six or ten port diaphragm valves for maximum analytical flexibility
- Micro-packed columns mounted in the center of the heated kiosk for stable performance over the analyzer's entire ambient temperature rating

The Heat Sink Oven of the Model 700 is a triangular shaped solid stainless-steel kiosk that can accommodate up to three chromatograph valves and two detectors. It also contains the chromatograph columns. This unique design, with oven temperatures up to 212°F (100°C), is standard for the Rosemount Analytical Model 700 Process Gas Chromatograph.



Columns

Since 1980, Emerson Process Management has been refining and improving its process for creating micro-packed columns. Rosemount Analytical micro-packed columns offer a superior combination of the features found in both capillary and conventional packed columns.

The result is improved chromatography with extended column life (several years in most applications without measurable degradation or bleed). Rosemount Analytical micro-packed columns produce sharper peaks for improved component separation, short analysis time and very low carrier-gas consumption.

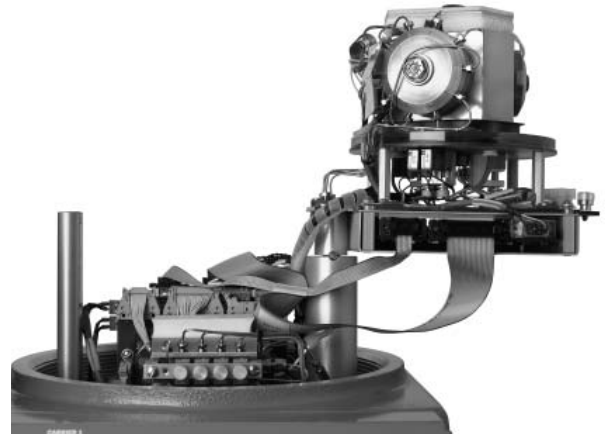

Maintenance of the Model 700 oven is simplified with all components mounted on the surface of the kiosk making access easy. Furthermore, the kiosk is mounted on a rotating plate that can be pivoted out of the way when access to other components is needed.

The Design Makes The Difference:

- Built tough to stand up against any environment
- Tested tough to insure performance
- Field-mountable technology means solid performance at reduced cost
- Valves built so well, they're guaranteed for life!
- Detector options that meet your requirements
- Micro-packed columns that are made to last

MON2000 Software

The Model 700 Process Gas Chromatograph is designed to operate unattended. If however, adjustments are needed; our exclusive MON2000 software allows complete control of your Gas Chromatographs – either locally or remotely. From within MON2000, a user can:

- Review and modify analytical settings
- Upload and display multiple chromatograms on the screen for comparison
- Upload and trend any of the measured results
- Export data for use in other 3rd party applications
- Overlay multiple chromatograms for troubleshooting and calibration
- Check original calibration against last calibration

The MON2000 Software is Windows®-based software designed to make analyzer configuration, maintenance and data collection easy. With intuitive drop-down menus and fill-in-the-blank tables, even new users can quickly navigate through the software.

The MON2000 software can display both current and multiple archived chromatograms on the screen streamlining the time needed to perform routine analyzer maintenance.

MON2000 also has a number of tools built in that help users manage their analyzers such as:

- Automatic recording of alarms in a log file
- Event logs that provide a continuous record of all operator changes with time and user name stored
- Maintenance log scratch pad for keeping track of maintenance or testing done

Data collected from the Process Gas Chromatographs can be stored and displayed in a wide range of options such as trend lines on the screen and logs automatically documenting all changes made to the Process Gas Chromatograph. Data can also be exported in formats compatible with most third-party Windows® applications.

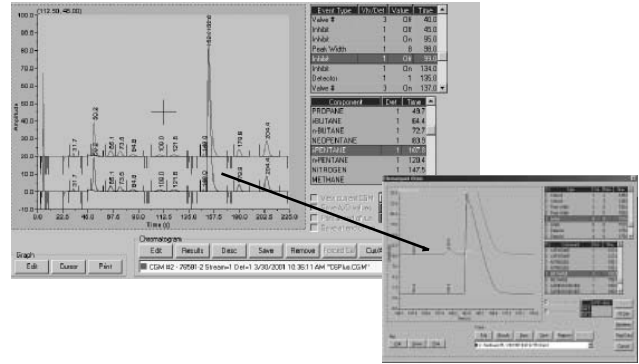

Comparing multiple chromatograms and zooming into specific sections is easy with the point and click design of MON2000.

Windows® is a registered trademark of Microsoft Corporation

Powerful Yet Simple – MON2000 Software

Simple Drop-Down Menus

Connect To Any GC With A Mouse Click

Full Featured Chromatogram Display

Summary Of Application Event Status and Time

Event Type	Vlv/Det	Value	Time
Detector	1	6	101.0
Inhibit	1	Off	105.0
Inhibit	1	On	145.0
Detector	1	5	150.0
Peak Width	1	8	160.0
Inhibit	1	Off	175.0
Inhibit	1	On	245.0
Detector	1	0	247.0

Automatic Listing Of Measured Components

Component	Det	Time
n-BUTANE	1	470.4
n-BUTANE	1	522.2
BUTENE-1	1	559.6
TRANS-2-BUTENE	1	601.8
CIS-2-BUTENE	1	638.4
1,3-BUTADIENE	1	666.4
CARBON DIOXIDE	1	743.2
ETHYLENE	1	771.0

Quickly Add Chromatograms To Overlay

Analyzer Networking and Data Communication

Emerson's Rosemount Analytical Process Gas Chromatographs can be configured in a number of networking and data communication schemes to meet most process communication requirements.

Options include Ethernet networks as well as multi-drop RS-485 networks. It is even possible to set up automatic polling for data collection over phone lines if desired.

Data communication options to the plant control system include simple analog and discrete signals as well as Modbus serial links. To preserve the integrity of the analysis data, all Model 700 Process Gas Chromatographs are capable of storing up to 99 days of analysis data in the event of loss of communication to the plant control system.

All Rosemount Analytical Process Gas Chromatographs are designed to operate unattended. Occasionally, adjustments to the analyzers' analytical method or a review of possible alarms may be needed. Using our exclusive MON2000 software loaded on either a PC or laptop running Windows®, you'll have complete control of your Process Gas Chromatographs – either locally or remotely.



The main electronics for the Model 700 Process Gas Chromatograph is mounted in a separate lower enclosure for protection of the electronics as well as providing easy accessibility.

Networking Flexibility

Whether you want to network Process Gas Chromatographs throughout the plant or simply link a single Gas Chromatograph to the DCS system, the Model 700 can be configured to handle most any scenario:

- Choice of Ethernet or RS-485 networks
- Can use the same network to connect Model 700, Model 500 and Model 1000 Process Gas Chromatographs
- Able to connect multiple PC workstations using MON2000
- Connectivity to plant control systems using industry standard protocols such as Modbus and OPC

Secure Modbus Connectivity

For Process Gas Chromatographs, Modbus continues to be the preferred choice to connect a Process Gas Chromatograph network to the plant control system. Modbus design avoids the use of central interface cards or computers that can act as a single-point of failure in the Modbus link. Instead, the plant DCS system can “talk” directly to each Process Gas Chromatograph to gather the data needed. Furthermore, the register and coil addresses can be easily customized to meet the specific data structure of the DCS. There is also a program built into the MON2000 workstation to test the Modbus link to the DCS if troubleshooting is needed.

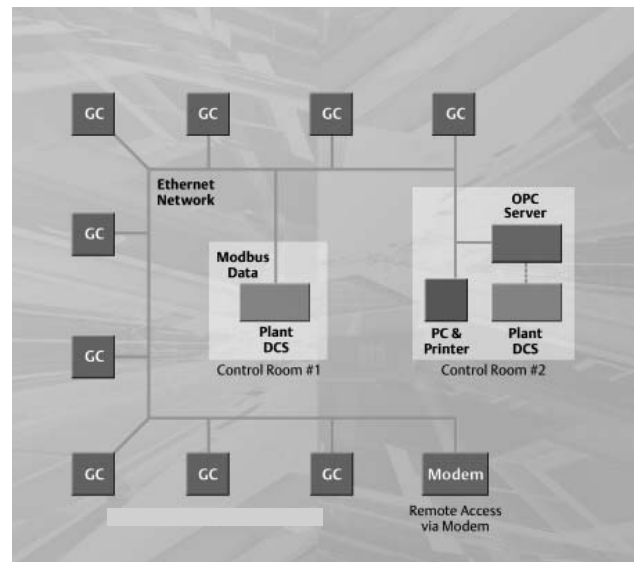

With Ethernet, analyzers transmit directly to the plant's digital control system (including DeltaV®) quickly and securely using either industry standard Modbus or the new OPC protocol.

Environmental Chamber Testing

Emerson Process Management provides the most thorough Process Gas Chromatograph testing in the world. Each Model 700 must operate to specification in our walk-in environmental test chambers cycling between 0°F and 130°F for 24 hours minimum. This is all part of our commitment to provide Process Gas Chromatographs that are capable of providing reliable measurements in the field.

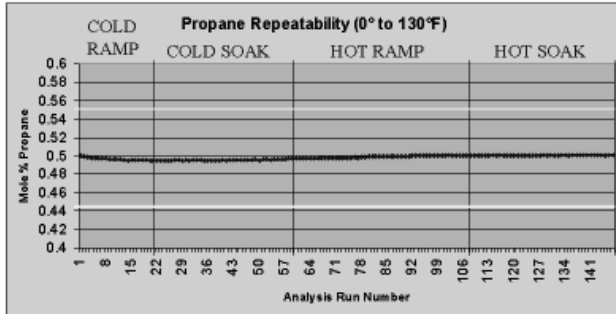

Legendary measurement stability in extreme climates is tested for every Model 700 Process Gas Chromatographs before it ships.

Custom Engineered Sample Systems

Any Process Gas Chromatograph is only as good as the quality of the sample it measures. So every sample system for Rosemount Analytical Process Gas Chromatographs is custom engineered for the specific requirements of the application. Common features include:

- Heated and open panel designs
- All components rated for the area classification
- Automatic calibration / validation available as an option
- Variety of sample probes to extract a reliable and stable sample from the process

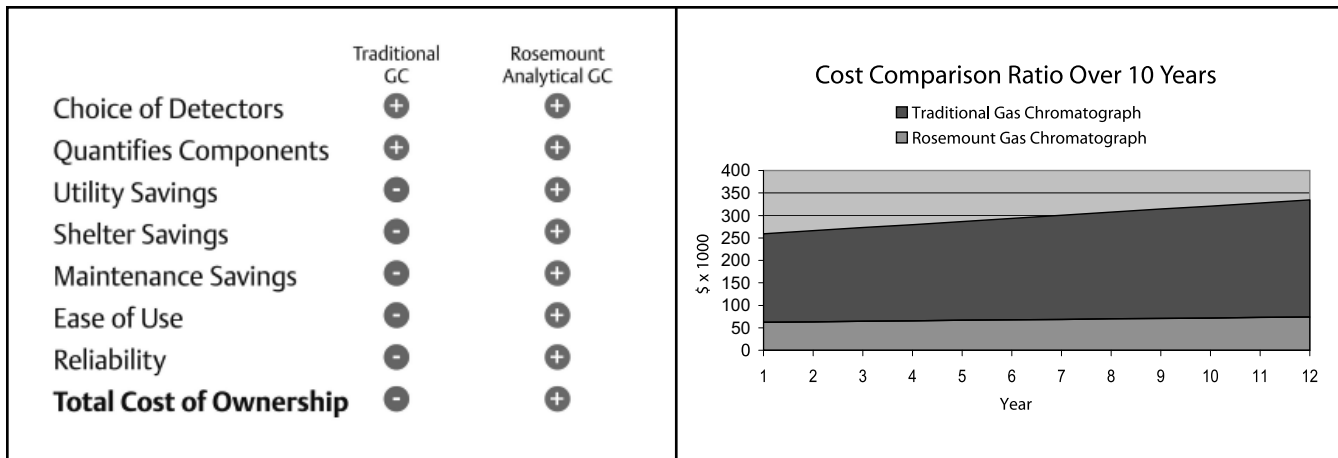
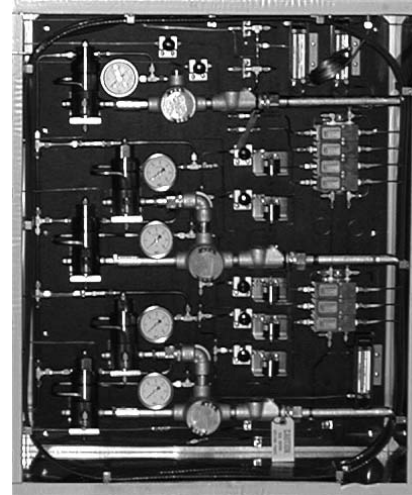

Lower Installation and Maintenance Cost

Rosemount Analytical Process Gas Chromatographs offer some of the lowest cost of ownership in the industry. Most process measurements can be made at or near the sample point greatly reducing the overall lifetime cost of the measurement. Expenses such as shelters, air conditioning, heating, long/heated sample lines can be

minimized or completely eliminated in most applications. Furthermore, Rosemount Analytical Process Gas Chromatographs are designed to operate unattended for long periods of time without adjustment. When adjustments are required, all components are easily accessible and can be performed in the field in minutes with standard tools.

Request A Quotation

Every Model 700 Process Gas Chromatograph is custom built for the specific application requested. To request a free quotation, simply fill out the information below and send it to the address at the end of this Data Sheet. You can also find an electronic version of the Request For Quotation form at our web site <http://www.raihome.com> .



Name: _____
 Title: _____
 Company: _____
 Address: _____

 Phone #: _____
 Fax #: _____
 Email: _____

Your Reference #: _____
 Project Name: _____
 Process Unit: _____
 Stream Name(s): _____

 Hazardous Area Classification: _____

Stream Composition	Units	Stream 1				Stream 2			
		Min	Normal	Max	Measure	Min	Normal	Max	Measure

(For more than two streams, make copies of this page)

	Stream 1	Stream 2
Stream Temperature:	_____	_____
Stream Pressure:	_____	_____
Stream Phase (vapor / liquid)	_____	_____
Stream Contaminants:	_____	_____
	_____	_____
	_____	_____

Distance to GC from Sample Point: _____

Mounting: Wall () Pipe () Stand () Power: 100-240 VAC () 24 VDC ()

Data Communication: Analog Output () Modbus () OPC () Printer () Modem ()

Analyzer Network: Ethernet () RS-485 Multi-Drop ()

Other Options: Carrier Gas () Calibration Gas () Start-Up () Training Class ()

Special Instructions: _____

MODEL 700 SPECIFICATIONS

Power:

Standard: 24 VDC, (21-30 VDC); 80 watts
 Optional: 90-264 VAC, 47-63 Hz; 80 watts
 80 watts start-up; 33 watts nominal

Environment: -29° to 60°C (-20° to 140°F)

Dimensions (without sample system):

Wall-Mount: 914mm H x 462mm W x 483mm D
 (36" H x 18.2" W x 19" D)
 Pipe-Mount: 914mm H x 462mm W x 645mm D
 (36" H x 18.2" W x 25.4" D)
 Floor-Mount: 1483mm H x 419mm W x 577mm D
 (58.4" H x 16.5" W x 22.7" D)

Mounting: Free-standing (standard) wall- or pipe- mount (optional)

Approximate Weight (without sample system): 80 kg (175 lbs.)

Area Safety Certification Options:

USA/Canada: CSA Class 1, Zone 1, Exd IIB (+H₂), T4
 Europe: ATEX Class 1, Zone 1, Aex d IIC, T4

Oven: Airless heat sink, maximum 100°C (212°F)

Valves: 6-port and 10-port diaphragm chromatograph valves Other types of valves may be used depending on the application such as liquid injection and rotary valves

Carrier Gas: Application dependent. Typically zero-grade helium, nitrogen or hydrogen at 90 psig

Detector: Thermal Conductivity Detector (TCD), Flame Ionization Detector (FID); TCD/TCD or TCD/FID dual detector configurations possible; Flame Photometric Detector (FPD) available (see FPD Module data sheet)

Gating Options: Fixed-Time, Slope and Automatic gating of peaks

Streams: Up to 8 streams (including calibration stream)

Analog Inputs: Four inputs filtered with transient protection (user scalable and assignable)

Analog Outputs: Four non-isolated analog outputs, 4 – 20 mA (standard); four additional isolated analog outputs or eight additional non-isolated analog outputs (optional)

Serial Communication Ports: Three serial ports standard with option for a total of seven. Depending on the port, choice of RS-232, RS-422 and RS-485 is available as well as the Modbus protocol

Digital Inputs: Five digital inputs; user assignable

Digital Outputs: One Gas Chromatograph alarm and four user assignable outputs (2 form C, 3 solid-state optically isolated)

Parallel Printer Port:

One parallel port available for printed reports

Internal Modem (optional):

Field-configurable; 300 to 33.6k baud rate

Ethernet Card (optional):

10 mbps with RJ-45 port

OUTLINE AND MOUNTING DETAILS

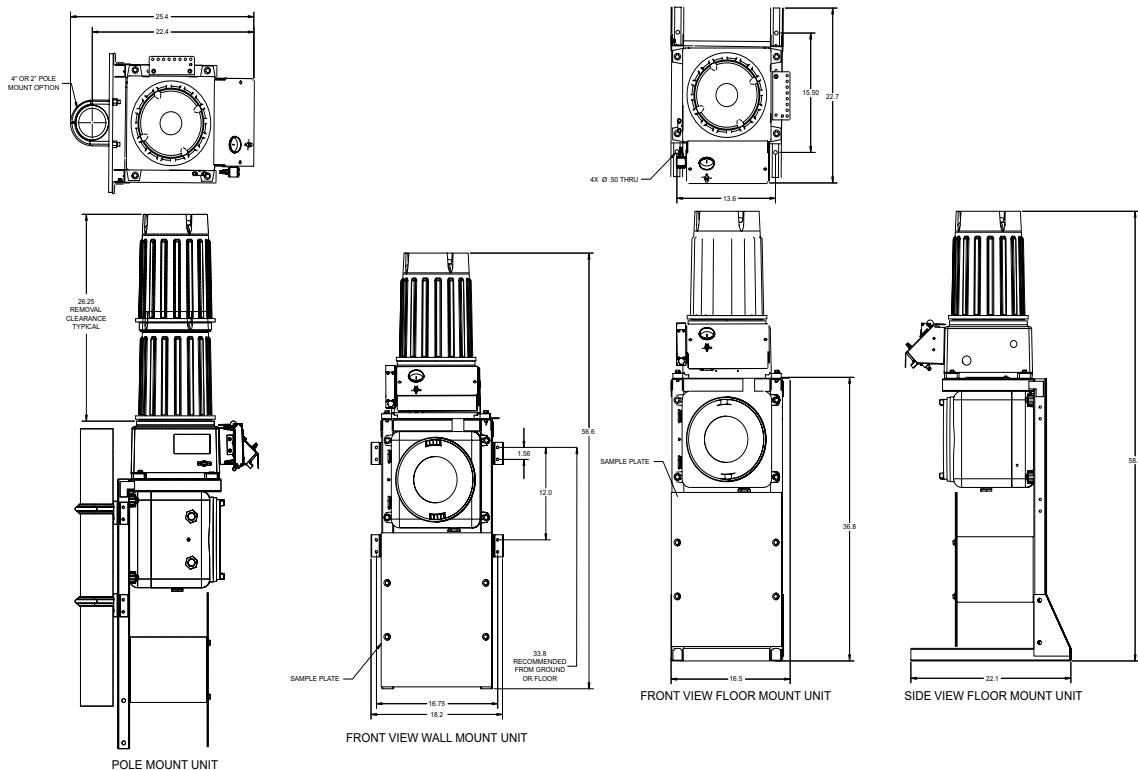

The contents of this publication are presented for informational purposes only, and while every effort has been made to ensure their accuracy, they are not to be construed as warranties or guarantees, express or implied, regarding the products or services described herein or their use or applicability. All sales are governed by our terms and conditions, which are available on request. We reserve the right to modify or improve the designs or specifications of our products at any time without notice.

Emerson Process Management

Rosemount Analytical Inc.

Process Analytic Division

5650 Brittmoore Road

Houston, TX 77041 USA

T: 713.827.6380, F: 713.827.3865

Toll Free in US and Canada: 1.866.GC.CENTER

Email: gc.csc@EmersonProcess.com

www.raihome.com

