

In Situ Oxygen Analyzer Packages

- Completely field-repairable probe
- Patented electronic cell protection
- Rugged 316 SS for all wetted parts
- HART® communications protocol provides calibration and troubleshooting capability from the control room
- Flexible electronics configuration
- Easy calibration
- No potentiometers to adjust
- Field-replaceable cell and heater/thermocouple design



WORLD CLASS TECHNOLOGY FROM THE WORLD LEADER

The Hagan in situ, zirconium oxide oxygen analyzer has long been established as the industry standard. The leader in oxygen flue gas analyzer technology, Rosemount Analytical has combined this Hagan expertise with state of the art features into one package – the World Class 3000 Oxygen Analyzer.

The World Class 3000 is completely field-repairable as internal components are conveniently accessible for in-house service personnel. For example, the heater/thermocouple probe assembly can be replaced and returned to service by in-house personnel in one-half hour or less. This repair is made without requiring the probe tube to be removed from the process.

The World Class 3000 analyzer offers flexible electronics configurations with the following components:

- IFT 3000 Intelligent Field Transmitter
- HART® Model 275 Handheld Interface
- MPS 3000 Multi-probe Test Gas Sequencer
- CRE 3000 Control Room Electronics
- HPS 3000 Field Interface Module

The HART communications protocol allows instrument technicians to interface with the probe's IFT 3000 Intelligent Field Electronics from the control room or any location where the 4-20 mA signal wires terminate. Service diagnostics and calibrations can be performed without requiring plant personnel to enter the often hot, inaccessible probe location.

Calibration data indicates the condition of the zirconium oxide sensor cell. Analyzer calibration requires no special equipment or knowledge and can be fully automated by incorporating the MPS 3000 Multi-probe Test Gas Sequencer. Cost is minimized and expansion is easy as the Multiprobe Test Gas Sequencer is a modular design for one to four World Class 3000 probes.

Rosemount Analytical also offers World Class 3000 Oxygen Analyzer packages suitable for operation in hazardous area locations (ie CENELEC EEXd). Please refer to product data sheet PDS-106-300NX.A01 for more information.

ROSEMOUNT®
Analytical

Visit our website at www.processanalytic.com
On-line ordering available.

EMERSON.
Process Management

THE WORLD CLASS 3000 OXYGEN ANALYZER IS COMPLETELY FIELD-REPAIRABLE



Diffusion Cell Assembly



Sensor Cell Assembly



Heater Thermocouple Assembly

OXYGEN SENSOR FEATURES AND BENEFITS

Features	Benefits
Rapid, accurate and reliable measurement of excess oxygen with a single, in situ probe.	Provides inputs for significant fuel savings that normally pay for the analyzer in less than one year. Significant enhancement in safety.
Electrodes are self-protected by patented electronic cell protection.	Provides long life for sensing element.
No sample system, sample probes, no scrubbers and no pumps are necessary; test gas calibration check without disturbing probe.	Low installation and low maintenance costs.
High speed of response.	Ideal for closed loop control.
Field-replaceable cell and heater/thermocouple assemblies.	Ease of maintenance.
Suitable for use in process temperatures up to 1300°F (700°C)	May be mounted near the combustion process.
Material of construction 316 LSS (all wetted parts).	High resistance to corrosion.
Sensitivity of cell increases logarithmically when oxygen decreases.	Very useful for low oxygen levels. Ideal for low excess air burners.

ADDITIONAL FEATURES

- Use with any fuel including coal or residual fuel burners. Standard sintered metal diffusion element keeps cell clean.
- Unique, patented electronic cell protection feature automatically protects sensor cell when analyzer detects reducing atmospheres.
- Output suitable for use with receivers such as indicators, recorders, controllers, data loggers or computers.
- Optional flame arrestor.
- Optional abrasive shield for extremely harsh environments.
- Certified versions available for hazardous areas.
- Optional arrangements for high temperature applications above 1300°F (700°C).
- Optional sealed junction box for high dust ambient environments.

WORLD CLASS 3000 OXYGEN ANALYZER DIMENSIONS

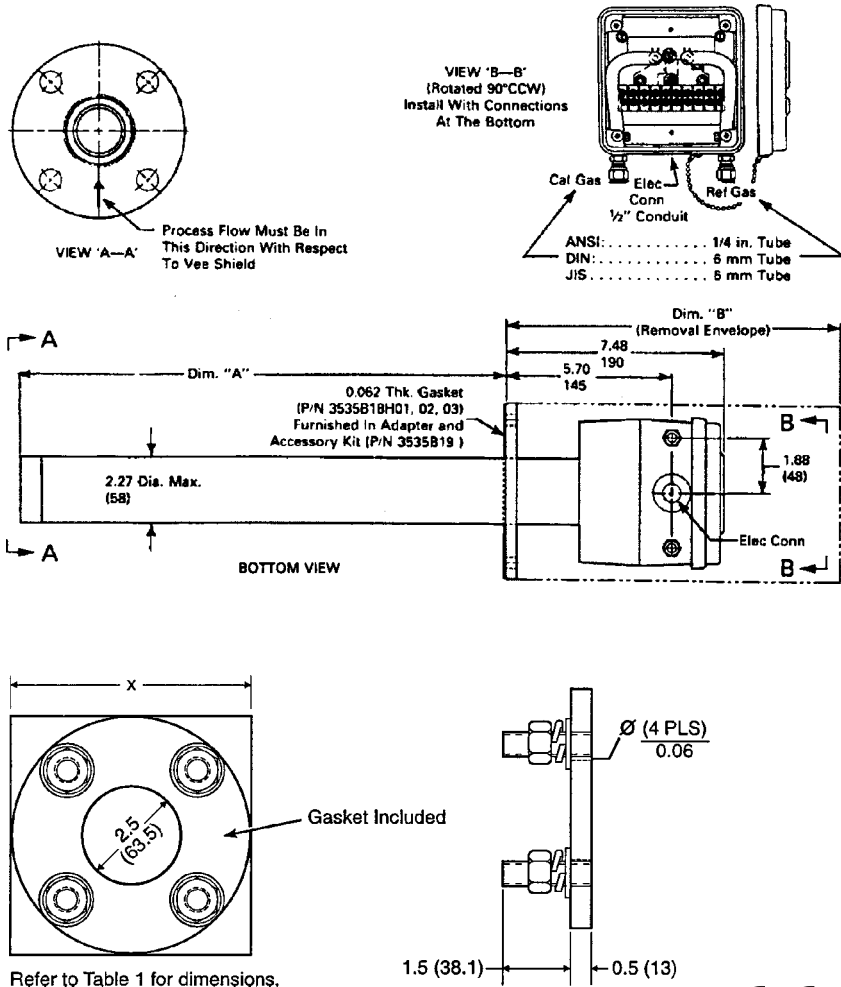

Installation Dimension Schedule

	Dimensions Dia. In. (mm)		
	ANSI	DIN	JIS
Flange (x)	6.00 (153)	7.5 (190)	6.5 (165)
Stud Size	5/8" - 11	M12 x 1.75	M16 x 2
4 Studs Eq. Sp. on B.C.	4.75 BC	5.12 BC	5.71 B.C

Table II. Removal/Installation*		
Probe Length	Dim. "A" Insertion Depth	Dim. "B" Removal Envelope
18 in. (457 mm) Probes	16.00 (407)	27.31 (694)
3 ft. (0.91 m) Probes	34.00 (864)	45.31 (1151)
6 ft. (1.83 m) Probes	70.00 (1778)	81.31 (2065)
9 ft. (2.74 m) Probes	106.00 (2692)	117.31 (2980)
12 ft. (3.66 m) Probes	143.00 (3607)	153.31 (3894)

* Add 3.75 (95) if using ceramic diffusion element and vee deflector.

Refer to Table 1 for dimensions.

Note: All dimensions are in inches with mm in parentheses.



Emerson Process Management has satisfied all obligations coming from the European legislation to harmonize the product requirements in Europe.

SPECIFICATIONS

OXYGEN PROBE

Probe lengths, nominal: 18 in. (457 mm), 3 ft. (0.91 m), 6 ft. (1.83 m), 9 ft. (2.74 m), 12 ft. (3.66 m) depending upon duct dimension

Probe material of construction: 316 LSS (all wetted parts)

Temperature limits for probe in process measurement area: 50° to 1300°F (10° to 700°C) to 1525°F (829°C), with shortened cell life

Ambient temperature limit for probe junction box: 300°F (149°C) [50° to 160°F (10° to 71°C) when used with Yokogawa electronics]

Resolution sensitivity – transmitted signal: 0.05% O₂

Probe reference

air flow (optional): 2 SCFH (1L/M) clean, dry, instrument quality air (20.95% O₂)

Calibration gas mixtures: Rosemount Test Gas Kit Part No. 6296A27G01 contains 0.4% O₂N₂ nominal and 8% O₂N₂ nominal

Calibration gas flow: 5 SCFH (2 L/M)

Approximate shipping weights:

18 in. (457 mm) package: 55 lb (24.97 kg)
3 ft. (0.91 m) package: 60 lb. (27.24 kg)
6 ft. (1.83 m) package: 66 lb. (29.94 kg)
9 ft. (2.74 m) package: 72 lb. (32.66 kg)
12 ft. (3.66 m) package: 78 lb. (35.38 kg)

All static performance characteristics are with operating variables constant. Specifications subject to change without notice.

WORLD CLASS 3000 ELECTRONICS CONFIGURATIONS

A World Class 3000 analyzer package typically includes an oxygen sensing probe, signal conditioning electronics and these optional accessories: mounting hardware, reference air set, calibration gas rotometer and up to 150 feet of cable.

The IFT 3000 Intelligent Field Transmitter provides a user interface, signal conditioning, diagnostics and calibration for single probe applications.

For applications where multiple oxygen analyzers are installed on site, Rosemount Analytical offers a multi-probe system. Up to eight (8) oxygen probes can be connected to one CRE 3000 Control Room Electronics.

Either of these electronics configurations provide semi-automatic calibration without requiring manual potentiometer adjustments. Additionally, the optional MPS 3000 Multi-probe Test Gas Sequencer provides fully automatic calibration by automatically introducing calibration gases.

The HPS 3000 Heater Power Supply permits the probe heater to be powered locally, eliminating lengthy runs of heavy-gauge power wiring between the field electronics and the probe.

WORLD CLASS 3000 PROBE WITH INTELLIGENT FIELD TRANSMITTER ELECTRONICS (for single probe applications)



***IFT 3000 Intelligent Field Transmitter
(Hazardous Area Deluxe Version)***

The IFT 3000 Intelligent Field Transmitter is shipped from the factory pre-set for 4-20 mA output representing 0 to 10% oxygen and alarm indication of fault conditions including high/low oxygen alarms with 3 relay outputs. Various other output signals and oxygen ranges are field-selectable.

The IFT 3000 electronics are housed in a standard NEMA 4X (IP65) enclosure for full weatherproof and corrosion protection.

The deluxe version has a large easy-to-read LED display for percent oxygen readout. A membrane keypad with a 4 x 20 character LCD display provides an easy-to-use interface for setting operating parameters and for viewing process and diagnostic data. When used with a stack thermocouple, stack temperatures and percent combustion efficiency are obtained. Manual, automatic and remote initiation of calibration is also available.

The IFT 3000 electronics are also available in a low-cost configurations with no LCD display or keypad. Both versions can be accessed via the HART® Model 275 Handheld Interface.

The HART communications protocol permits all operator functions to also be performed from the control room, utilizing the same twisted pair of wires that carry the 4-20 mA output signal. The HART Model 275 Handheld Interface permits operator interface into the IFT 3000 Electronics from anywhere the 4-20 mA signal terminates.

COMMUNICATE WITH THE IFT 3000 ELECTRONICS FROM ALMOST ANYWHERE VIA HART® COMMUNICATIONS

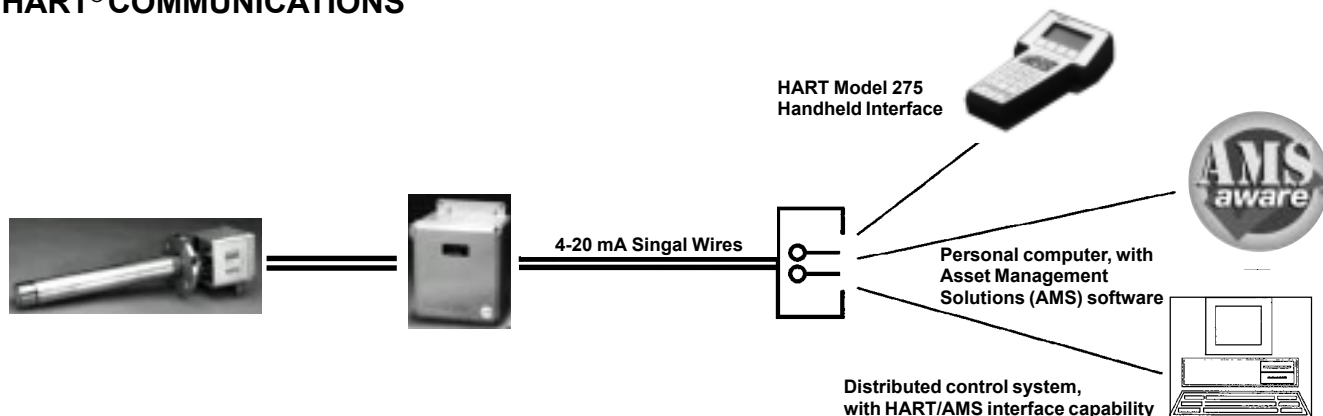

FEATURES

- Probe heater over-temperature protection uses software and hardware disable. With HPS 3000, hardware disable requires optional cable.
- Optional HPS 3000 Heater Power Supply allows probe and IFT 3000 field electronics distances of up to 1200 ft. (400 m).
- Certified versions available for use in hazardous areas. See Product Data Sheet PDS 106-300NX.
- Standard World Class 3000 Intelligent Field Transmitter (IFT 3000) guides the user through the calibration procedure. Output can be tracked or held during calibration.
- Optional MPS 3000 Multi-probe Test Gas Sequencer provides fully automatic test gas sequencing for up to four (4) World Class 3000 probes.

IFT 3000 SYSTEM DIAGRAM

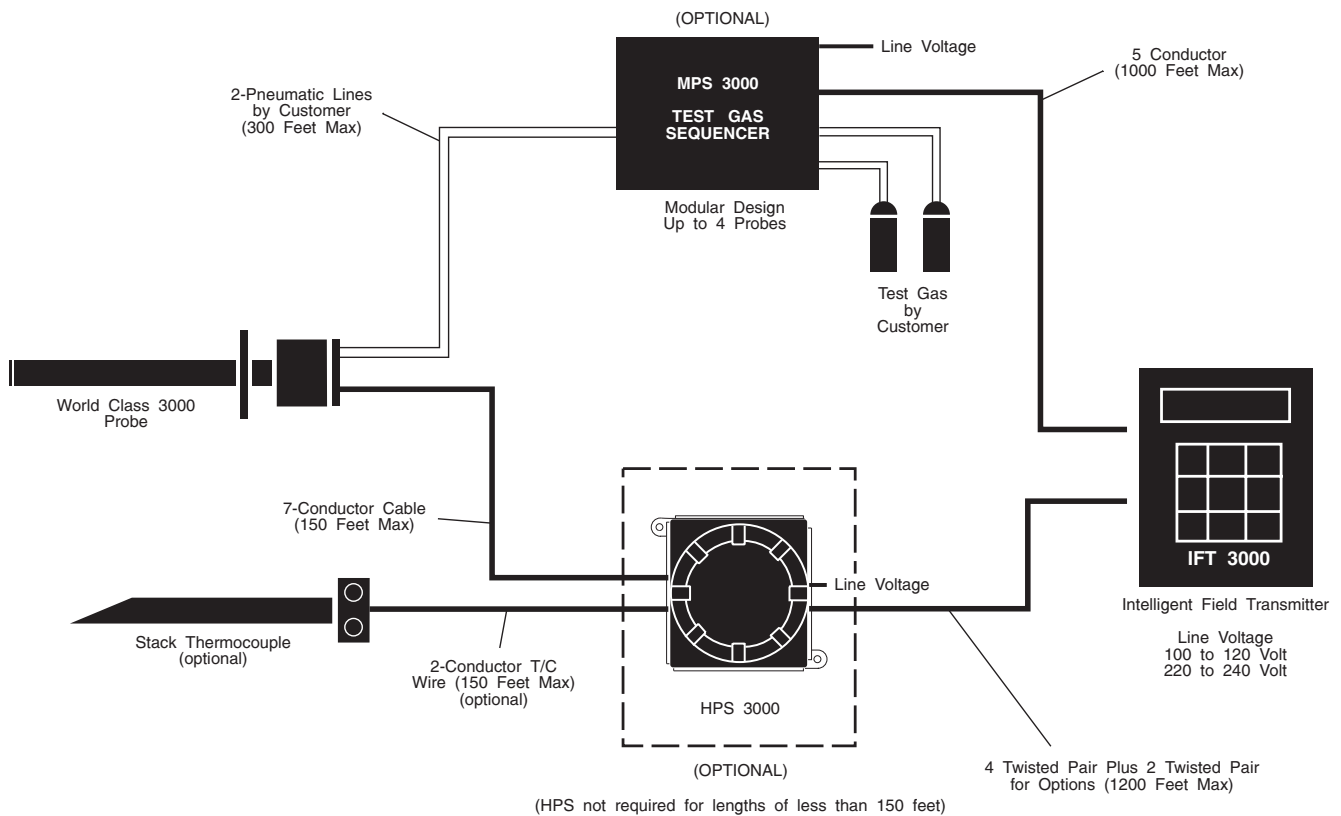

IFT 3000 INTELLIGENT FIELD TRANSMITTER

Housing classification:	NEMA 4X (IP65)
Humidity range:	95% relative humidity
Ambient temperature range:	32° to 120°F (0° to 50°C)
Vibration:	5 m/sec ² , 10 to 500 xyz plane
External electrical noise:	Meets EMC requirements for RFI immunity
Power supply:	100/115/220V ± 10% VAC at 50/60 Hz
Power requirement:	
With HPS 3000:	30 VA
Without HPS 3000:	275 VA
O₂ range:	Field-selectable – log or linear, variable range, dual range, range switching or (0-1%, 0-5%, 0-10%, 0-25%)
Analog outputs:	1 isolated output: 0-20 mAdc, 4-20 mAdc into 950 ohm maximum, 0-10 VDC into 2K ohm minimum

O₂ Indication (analog output):	0.1% O ₂ or ± 3% of reading, whichever is greater
System speed or response (amplifier output):	Less than 3 seconds
Resolution sensitivity – transmitted signal:	0.05% O ₂
Programmable contact outputs:	3 available, Form-C, 48 V maximum, 100 mA maximum
Displays:	0.8 in. (1, 2 cm) high, 3-digit numeric LED display
Operator interface:	Deluxe version: 4 line by 40-character backlight LCD alphanumeric display; 8-key general purpose keyboard
Approximate shipping weight:	49 lbs. (22 kg)
Languages available:	English, French, German, Italian, Spanish

All static performance characteristics are with operating variables constant. Specifications subject to change without notice.

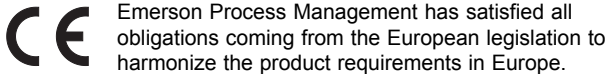

IFT 3000 (Intelligent Field Electronics) Dimensional Drawing

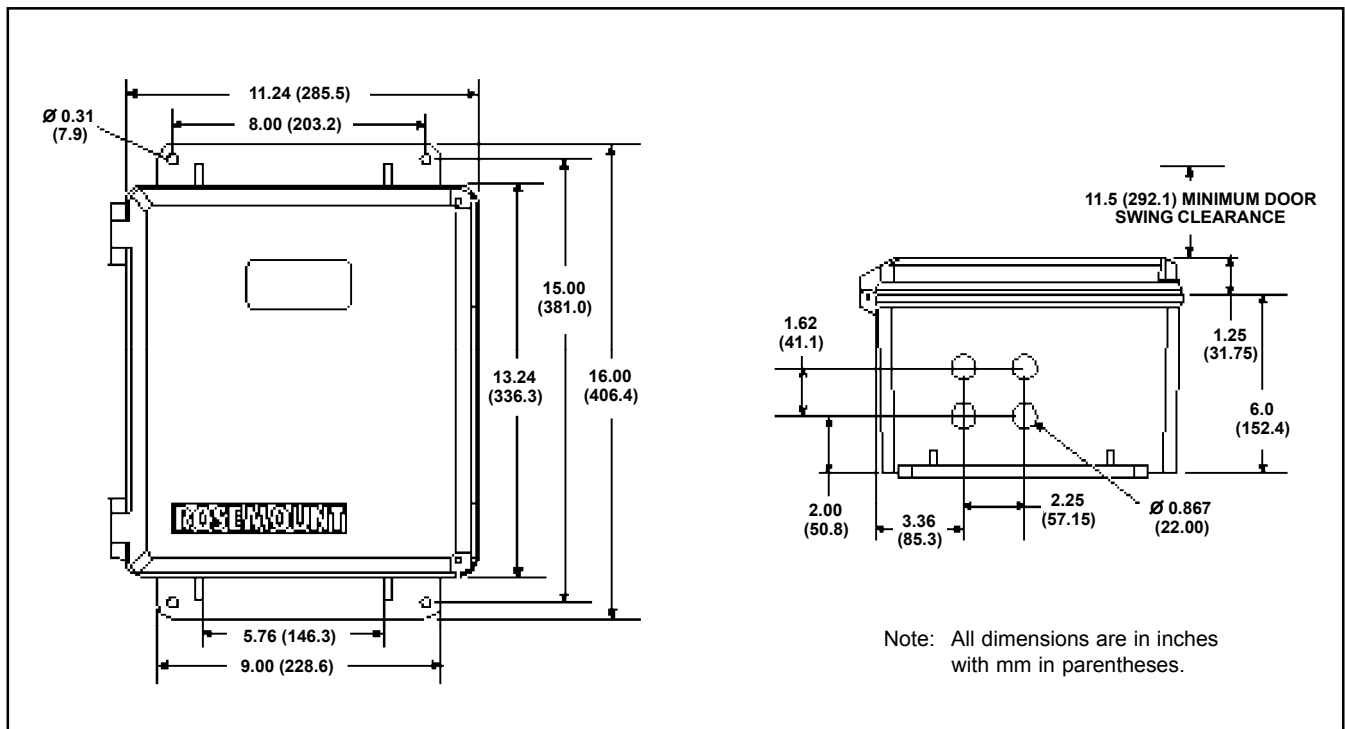

WORLD CLASS 3000 WITH IFT ELECTRONICS – ORDERING INFORMATION

3001NH	World Class 3000 Oxygen Analyzer with Intelligent Field Electronics Package
--------	---

Oxygen Transmitter – Instruction Book

Code	Sensing Probe Type
1	Ceramic diffusion element probe (ANSI)
2	Flame arrestor probe (ANSI) – FM-approved package (ceramic diffusion element)
3	Snubber diffusion element (ANSI)
4	Ceramic diffusion element probe (DIN)
5	Flame arrestor probe (DIN) – (snubber diffusion element)
6	Snubber diffusion element (DIN)
7	Ceramic diffusion element probe (JIS)
8	Flame arrestor probe (JIS) – FM-approved package (ceramic diffusion element)
9	Snubber diffusion element (JIS)

Code	Probe Assembly
0	18" probe
1	18" probe with 3' bypass ²
2	3' probe
3	3' probe with abrasive shield ²
4	6' probe
5	6' probe with abrasive shield ²
6	9' probe ²
7	9' probe with abrasive shield ²
8	12' probe ²
9	12' probe with abrasive shield ²

Code	Mounting (Stack Side)
0	No adapter plate ("0" must also be chosen under Mounting below, also)
1	Mounting to stack (new installation)
2	Mounting to Model 218 mounting plate (with Model 218 shield removed)
3	Mounting to existing Model 218 support shield
4	Mounting into competitor's mount
5	Model 132 / World Class 3000 adapter plate

Code	Mounting (Probe Side)
0	No adapter plate
1	Mounting probe only (ANSI)
2	Mounting a new bypass or abrasive shield (ANSI)
4	Mounting probe only (DIN)
5	Mounting a new bypass or abrasive shield (DIN)
7	Mounting probe only (JIS)
8	Mounting a new bypass or abrasive shield (JIS)

Code	Arrangement
00	No hardware
11	Calibration gas rotometer and reference gas set
21	MPS 3000

Code	HPS 3000 ¹
0	None
1	NEMA 4X HPS 3000 (IP 65)
2	Class 1, Division 1, Group B, HPS 3000
3	CENELEC-certified HPS 3000

3001NH	3	4	1	1	21	0	Example – continued
--------	---	---	---	---	----	---	---------------------

WORLD CLASS 3000 WITH IFT ELECTRONICS – ORDERING INFORMATION (continued)

Code	Power for HPS 3000
0	No HPS provided
1	115 V
3	220 V/240 V
7	100 V

Code	Intelligent Field Transmitter Power
1	115 V
2	115 V with enclosure heater
3	220 V
4	220 V with enclosure heater
5	110 V
6	100 V with enclosure heater

Code	Intelligent Field Transmitter Style
5	Blind IFT with HART® capability
7	Deluxe IFT with HART® capability

Code	Languages
20	German
30	French
40	Italian
50	English
60	Spanish

Code	Probe Cable (Weatherproof) to HPS or IFT
00	No cable
11	6 m (20 ft.)
12	12 m (40 ft.)
13	18 m (60 ft.)
14	24 m (80 ft.)
15	30 m (100 ft.)
16	45 m (150 ft.)

(Cont'd)	0	1	5	50	12	
----------	---	---	---	----	----	--

Special sensing cells are available for applications where high levels of SO₂ or HCl are present.

NOTES:

- ¹ The cable between HPS 3000 and IFT 3000 as listed below: Order per length – maximum 1200 ft. (360 m)
List Part Number As Separate Line Item

Code	Description
1A97968H01 (Length – Ft.)	4 – Twisted Pair 22 AWG Shielded

- ² Recommended usages: high velocity particulates in flue stream, installation within 3.5m (10 ft.) of soot blowers or heavy salt cake build up. Applications: pulverized coal, recovery boilers, lime kiln. Support brackets are supplied with shields. Shields are recommended for all 9' and 12' probes.

ACCESSORIES

1. MPS 3000 Multi-probe Gas Sequencer
2. Probe Mounting Jacket or Bypass Package for high temperature applications

WORLD CLASS 3000 MULTI-PROBE APPLICATION WITH CONTROL ROOM ELECTRONICS (for multi-probe applications)



CRE 3000 Control Room Electronics Module

For applications where multiple oxygen analyzers will be installed on-site, the World Class 3000 Oxygen Analyzer together with the CRE 3000 Control Room Electronics module is a cost-effective solution.

The CRE 3000 Control Room Electronics allow interaction with up to eight World Class 3000 probes via the HPS 3000 Field Interface Module.

This flexible, easily expanded electronics arrangement allows the World Class 3000 probes to be linked to the control room electronics without the added cost of requiring intelligent field electronics.

The CRE 3000 improves the accuracy of the combustion control process as it averages the oxygen results thereby reducing errors due to stratification. Up to 4 averages of any probe combinations can be user-defined.

FEATURES

- The Control Room Electronics module (CRE 3000) can interface with up to eight (8) World Class 3000 probes. Provides all necessary intelligence for controlling the probe and optional MPS 3000 Multi-probe Gas Sequencer.
- The CRE 3000 Electronics provide user friendly, menu-driven operator interface with context-sensitive, on-line help.
- The CRE 3000 Electronics averages the process data as defined by user. This reduces inaccuracies due to stratification.
- Remote contact initiates calibration. During calibration, the probe is removed from average.
- HPS 3000 Field Interface Module permits the probe heater to be powered locally, minimizing long lengths of heavy-gauge power cable.
- The optional MPS 3000 Multi-probe Test Gas Sequencer provides fully automatic test gas calibration and reference air for up to four (4) World Class 3000 probes. MPS 3000 can be located up to 300 ft. (91 m) from World Class 3000 probe.
- Optional stack temperature and combustion efficiency measurement; stack thermocouple required.
- Probe heater over-temperature protection with software disable as standard. Hardware disable (line voltage relay) requires one additional twisted pair of HPS/CRE cable.
- Any probe failure will cause removal from average.
- CRE 3000 electronics stages calibrations so that no two probes calibrate simultaneously.

CRE 3000 SYSTEM DIAGRAM

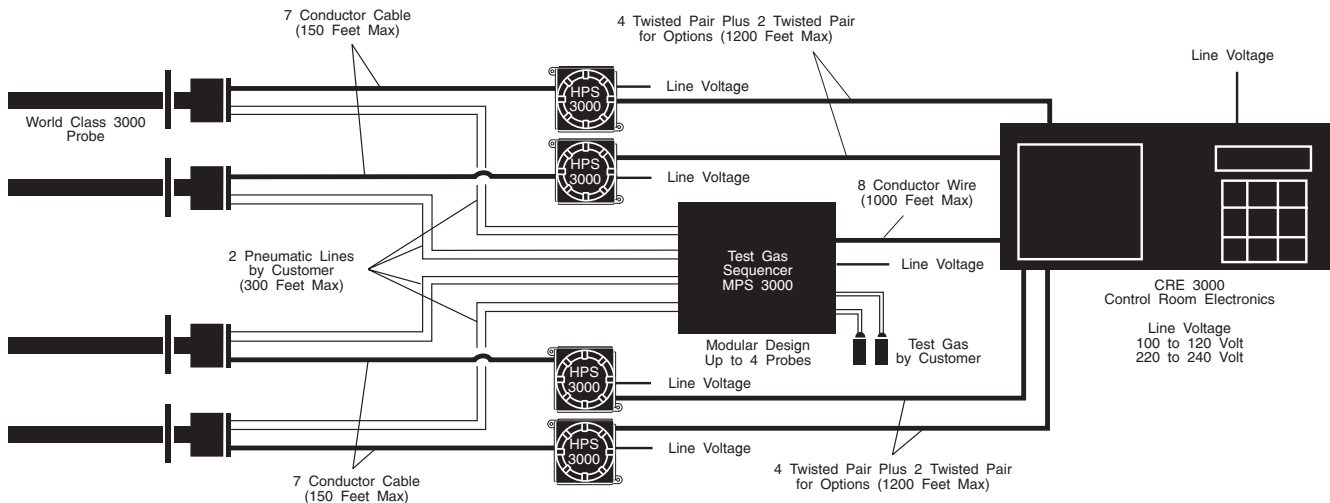

CRE 3000 CONTROL ROOM ELECTRONICS

Ambient environment requirements: Clean, dry

Ambient temperature range: 4° to 120°F (4° to 50°C)

Vibration: Slight: 30-degree drop test

Number of probes: 8 maximum

Analog outputs: 2-12 isolated outputs: 0-20 mAdc, 4-20 mAdc into 950 ohm maximum, 0-10 VDC into 2K ohm minimum

O₂ indication (analog output): ± 0.1% O₂ or ± 3% of reading, whichever is greater

Power supply: 100/115/220/240V ± 10% VAC at 50/60 Hz

Power requirements: 100 VA

System speed or response (amplifier output): Less than 3 seconds

Resolution sensitivity transmitted signal: 0.05% O₂

O₂ range: Field-selectable – log or linear, variable range, range switching or (0-1%, 0-5%, 0-10%, 0-25%)

Averaging: 4 user-definable averages of 2 to 8 probes

Programmable contact outputs: 8 available, Form-C, 48 V maximum, 100 mA maximum

Indicators: LED indicators for system failure (failure description available on LED panel). Calibration in progress for each of 8 probes, O₂ hi/lo alarm for each of 8 probes

Programmable displays: 2 line, 0.8 in. (2 cm) high, 8-digit, alphanumeric LED displays for individual or averaged results

Operator interface: 4-line by 20-character backlight LCD alphanumeric display; 8-key general purpose keyboard

Approximate shipping weight: 35 lbs. (16 kg)

CE Emerson Process Management has satisfied all obligations coming from the European legislation to harmonize the product requirements in Europe.

All static performance characteristics are with operating variables constant. Specifications subject to change without notice.

CRE 3000 Housing Dimensional Drawing

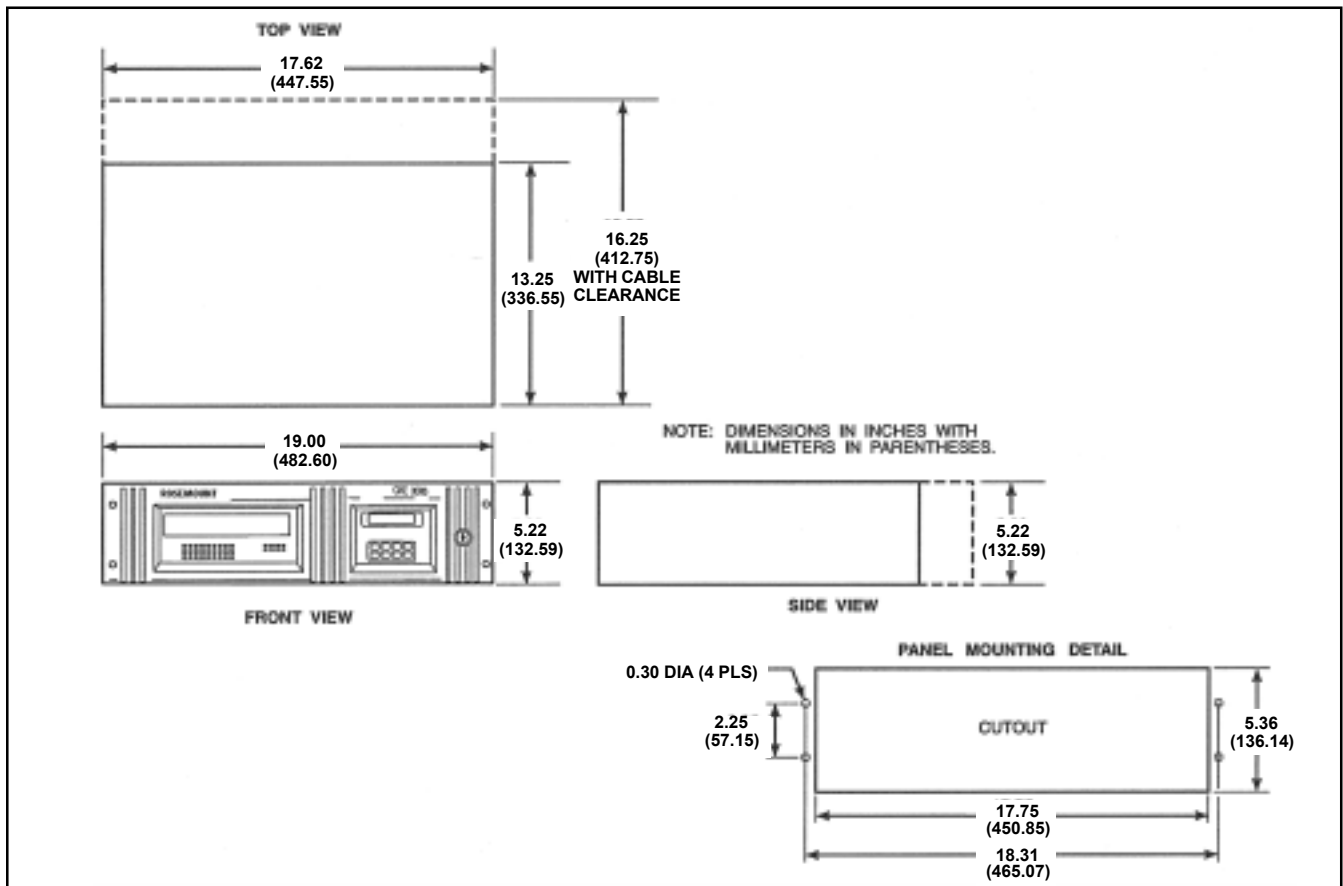

WORLD CLASS 3000 WITH CRE ELECTRONICS – ORDERING INFORMATION

World Class 3000 Oxygen Analyzer with Control Room Electronics Package

Oxygen Analyzer – Instruction Book

Code	Sensing Probe Type
1	Ceramic diffusion element probe (ANSI)
2	Flame arrestor probe (ANSI) – FM-approved package (ceramic diffusion element)
3	Snubber diffusion element (ANSI)
4	Ceramic diffusion element probe (DIN)
5	Flame arrestor probe (DIN) – (snubber diffusion element)
6	Snubber diffusion element (DIN)
7	Ceramic diffusion element probe (JIS)
8	Flame arrestor probe (JIS) (ceramic diffusion element)
9	Snubber diffusion element (JIS)

Code	Probe Assembly
0	18" probe
1	18" probe with 3' bypass ²
2	3' probe
3	3' probe with abrasive shield ³
4	6' probe
5	6' probe with abrasive shield ³
6	9' probe
7	9' probe with abrasive shield ³
8	12' probe
9	12' probe with abrasive shield ³

Code	Mounting (Stack Side)
0	No adapter plate ("0" must also be chosen under Mounting below, also)
1	Mounting to stack (new installation)
2	Mounting to Model 218 mounting plate (with Model 218 shield removed)
3	Mounting to existing Model 218 support shield
4	Mounting into competitor's mount
5	Model 132 / World Class 3000 adaptor plate

Code	Mounting (Probe Side)
0	No adapter plate
1	Mounting probe only (ANSI)
2	Mounting a new bypass or new abrasive shield (ANSI)
4	Mounting probe only (DIN)
5	Mounting a new bypass or new abrasive shield (DIN)
7	Mounting probe only (JIS)
8	Mounting a new bypass or new abrasive shield (JIS)

Code	Arrangement
0	No hardware
1	Calibration gas rotometer and reference gas set
2	MPS 3000

3001NC	6	2	1	4	2	EXAMPLE – continued
--------	---	---	---	---	---	---------------------

**WORLD CLASS 3000 WITH CRE ELECTRONICS – ORDERING INFORMATION
(continued)**

(Cont'd)	Code	Arrangement																
	2	CRE 3000 (2 to 8 probes)																
		<table border="1"> <thead> <tr> <th>Code</th> <th>HPS 30000 ¹</th> </tr> </thead> <tbody> <tr> <td>1</td> <td>NEMA 4X (IP 65)</td> </tr> <tr> <td>2</td> <td>Class 1, Division 1, Group B</td> </tr> <tr> <td>3</td> <td>CENELEC-certified HPS 3000</td> </tr> </tbody> </table>	Code	HPS 30000 ¹	1	NEMA 4X (IP 65)	2	Class 1, Division 1, Group B	3	CENELEC-certified HPS 3000								
Code	HPS 30000 ¹																	
1	NEMA 4X (IP 65)																	
2	Class 1, Division 1, Group B																	
3	CENELEC-certified HPS 3000																	
		<table border="1"> <thead> <tr> <th>Code</th> <th>HPS 3000 Power</th> </tr> </thead> <tbody> <tr> <td>1</td> <td>115 V</td> </tr> <tr> <td>2</td> <td>220/240 V</td> </tr> <tr> <td>3</td> <td>100 V</td> </tr> </tbody> </table>	Code	HPS 3000 Power	1	115 V	2	220/240 V	3	100 V								
Code	HPS 3000 Power																	
1	115 V																	
2	220/240 V																	
3	100 V																	
		<table border="1"> <thead> <tr> <th>Code</th> <th>Probe Cable (Weatherproof) to HPS ¹</th> </tr> </thead> <tbody> <tr> <td>00</td> <td>No Cable</td> </tr> <tr> <td>11</td> <td>6 m (20 ft.)</td> </tr> <tr> <td>12</td> <td>12 m (40 ft.)</td> </tr> <tr> <td>13</td> <td>18 m (60 ft.)</td> </tr> <tr> <td>14</td> <td>24 m (80 ft.)</td> </tr> <tr> <td>15</td> <td>30 m (100 ft.)</td> </tr> <tr> <td>16</td> <td>45 m (150 ft.)</td> </tr> </tbody> </table>	Code	Probe Cable (Weatherproof) to HPS ¹	00	No Cable	11	6 m (20 ft.)	12	12 m (40 ft.)	13	18 m (60 ft.)	14	24 m (80 ft.)	15	30 m (100 ft.)	16	45 m (150 ft.)
Code	Probe Cable (Weatherproof) to HPS ¹																	
00	No Cable																	
11	6 m (20 ft.)																	
12	12 m (40 ft.)																	
13	18 m (60 ft.)																	
14	24 m (80 ft.)																	
15	30 m (100 ft.)																	
16	45 m (150 ft.)																	
Cont'd	2	1	1	11														

Special sensing cells are available for applications where high levels of SO₂ or HCl are present.

NOTES:

¹ HPS 3000 is required and cable is between probe and HPS 3000.

² 3 ft. Inconel 600 Bypass Package process temperature up to 1050°C (1922°F). For extended lengths, or higher temperature ranges, see World Class 3000 accessories. Extended temperature bypass with Kanthol alloys may also be provided 1300°C (2400°F).

³ Recommended usages: high velocity particulates in flue stream, installation within 3.5M (10 ft.) of soot blowers or heavy salt cake built up. Applications: pulverized coal, recovery boilers, lime kiln. Support brackets are provided with abrasive shields.

EXCHANGE/UPGRADE OF EXISTING OXYGEN ANALYZER UTILIZING EXISTING ELECTRONICS



Upgrade your old oxygen analysis system with the World Class 3000 Oxygen Analyzer! The World Class 3000 probe may be operated using older existing Westinghouse/Hagan, Rosemount Analytical, or selected competitive electronics. Rosemount Analytical will offer a credit for existing probes shipped to our factory.

FEATURES

- For replacement of these existing probes:
 - Westinghouse/Hagan
 - Rosemount Analytical
 - Most competitive probes
- Available with either a 115 V or 44 V heater

3001DR Direct Replacement Model

Utilize 115V heater, minimizing installation difficulty – No HPS 3000 Heater Power Supply is required

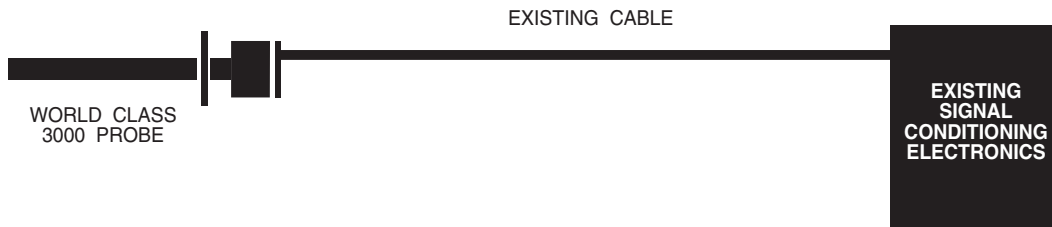

OR

3001NE Exchange Model (utilizes extended life 44V heater with HPS 3000 Module)

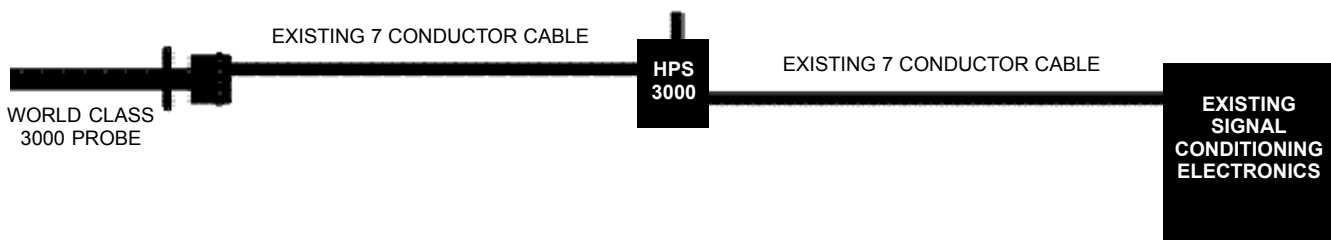

3001DR EXCHANGE MODELS ORDERING INFORMATION

3001DR	Direct Replacement World Class 3000 Exchange Probe for Westinghouse/Rosemount 132/218/225/218A, or any competitive probe (includes 115V heater, no HPS required)
---------------	---

Exchange Probe – Instruction Book
--

Code	Sensing Probe Type
1	Ceramic diffusion element probe (ANSI)
2	Flame arrestor probe (ANSI) (ceramic diffusion element) ¹
3	Snubber diffusion element (ANSI)
4	Ceramic diffusion element probe (DIN)
5	Flame arrestor probe (DIN) (snubber diffusion element)
6	Snubber diffusion element (DIN)
7	Ceramic diffusion element probe (JIS)
8	Flame arrestor probe (JIS) (ceramic diffusion element)
9	Snubber diffusion element (JIS)

Code	Probe Assembly
0	18" probe
2	3' probe
3	3' probe with abrasive shield ⁵
4	6' probe
5	6' probe with abrasive shield ⁵
6	9' probe
7	9' probe with abrasive shield ⁵
8	12' probe
9	12' probe with abrasive shield ⁵

Code	Mounting (To Stack or Existing Mounting Plate) ²
0	No adapter plate
1	Mounting to stack (new installation)
2	Mounting to Model 218 mounting plate (with Model 218 shield removed)
3	Mounting into existing Model 218 support shield or bypass
4	Mounting into competitor's mount ³
5	Model 132 / World Class 3000 adaptor plate

3001DR	3	2	2	EXAMPLE – continued
--------	---	---	---	---------------------

3001NE EXCHANGE MODELS ORDERING INFORMATION

3001NE	Standard World Class 3000 Exchange Probe, replacing Westinghouse/Rosemount 132/218/225/218A, or any competitive probe (includes HPS 3000 Electronics).
---------------	---

Exchange Probe – Instruction Book
--

Code	Sensing Probe Type
1	Ceramic diffusion element probe (ANSI)
2	Flame arrestor probe (ANSI) (ceramic diffusion element) ¹
3	Snubber diffusion element (ANSI)
4	Ceramic diffusion element probe (DIN)
5	Flame arrestor probe (DIN) ¹ (snubber diffusion element)
6	Snubber diffusion element (DIN)
7	Ceramic diffusion element probe (JIS)
8	Flame arrestor probe (JIS) ¹ (ceramic diffusion element)
9	Snubber diffusion element (JIS)

Code	Probe Assembly
0	18" probe
2	3' probe
3	3' probe with abrasive shield ⁵
4	6' probe
5	6' probe with abrasive shield ⁵
6	9' probe
7	9' probe with abrasive shield ⁵
8	12' probe
9	12' probe with abrasive shield ⁵

Code	Mounting (To Stack or Existing Mounting Plate) ²
0	No adapter plate
1	Mounting to stack (new installation)
2	Mounting to Model 218 mounting plate (with Model 218 shield removed)
3	Mounting into existing Model 218 support shield or bypass
4	Mounting into competitor's mount ³
5	Mounting 132 / World Class 3000 adaptor plate

3001NE	3	2	2	EXAMPLE – continued
--------	---	---	---	---------------------

WORLD CLASS 3000 ACCESSORIES



Optional HPS 3000 Field Interface-NEMA 4X (IP65)
(Explosion-proof version optional)



HART® Model 275 Handheld Interface



Optional MPS 3000 Multi-probe Test Gas Sequencer

HPS 3000 FIELD INTERFACE ELECTRONICS

[for use with CRE 3000 or optional with IFT 3000 for probe electronics distances greater than 150 ft. (45 m)]

Housing classification: NEMA 4X (IP65) optional
Class 1, Div. 1, Groups B, C, D

Humidity range: 95% relative humidity

Ambient temperature range: 32° to 140°F (0° to 60°C)

Cabling distance between HPS 3000 and probe: Maximum 150 ft. (45 m)

Power supply: 100/115/220V ± 10% VAC at 50/60 Hz

Vibration: 5 m/sec², 10 to 500 xyz plane

External electrical noise: Meets EMC requirements for RFI immunity

Power requirement: 200 VA

Approximate shipping weight: 20 lbs. (9 kg)

All static performance characteristics are with operating variables constant. Specifications subject to change without notice.

CE Emerson Process Management has satisfied all obligations coming from the European legislation to harmonize the product requirements in Europe.

Optional HPS 3000 Field Interface

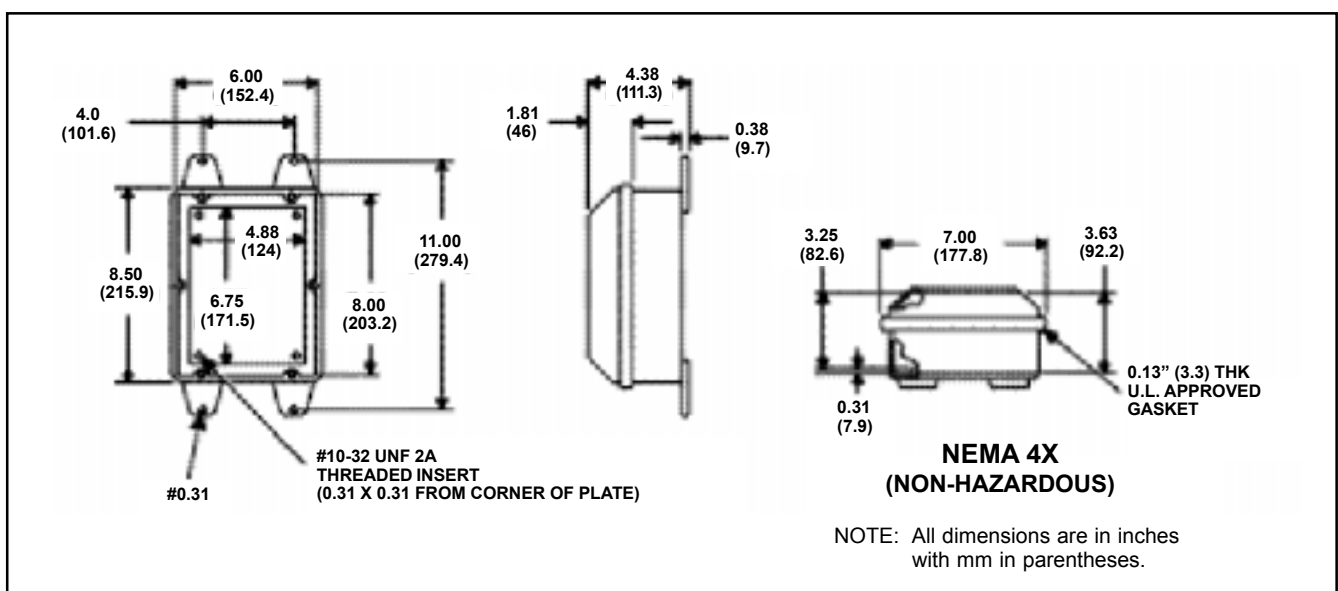

WORLD CLASS 3000 ACCESSORIES (continued)

MPS 3000 MULTI-PROBE TEST GAS SEQUENCER (optional)

Housing classification:	NEMA 4X (IP65)
Humidity range:	95% relative humidity
Ambient temperature range:	-20° to 160°F (-30° to 71°C)
Vibration:	5 m/sec. ² , 10 to 500 xyz plane
External electrical noise:	Meets EMC requirements for RFI immunity
Calibration interval:	From 1 hour to 1 year (with WC 3000 electronics)
Calibration duration:	10 sec. to 20 min. (with WC 3000 electronics)
After calibration purge time:	30 sec. to 20 min. (with WC 3000 electronics)

Piping distance between MPS 3000 and probe:	Maximum 300 ft. (90 m)
Cabling distance between MPS 3000 and WC 3000 electronics:	Maximum 1000 ft. (300 m)
Power Supply:	100/115/220V ± 10% VAC at 50/60 Hz
Power requirement:	15 VA
Approximate shipping weight:	35 lbs. (16 kg)
Piping requirements:	1/8" o.d. tubing, 1/8" NPT bulkhead connectors (high gas in, low gas in, ref air in, 4 x test gas out, 4 x ref air out)

All static performance characteristics are with operating variables constant. Specifications subject to change without notice.

CE Emerson Process Management has satisfied all obligations coming from the European legislation to harmonize the product requirements in Europe.

Optional MPS 3000 Multi-probe Gas Sequencer

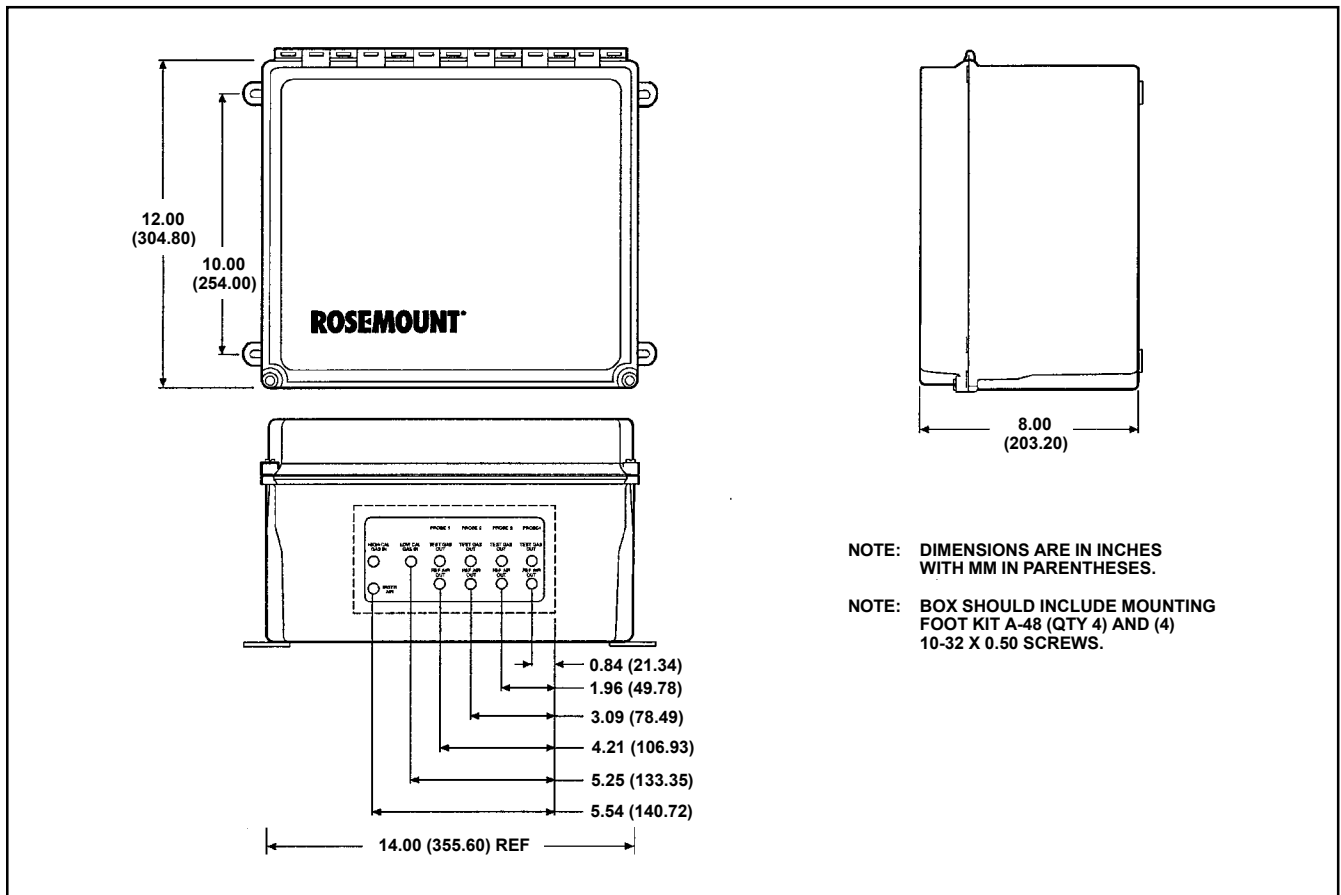

WORLD CLASS 3000 ACCESSORIES (continued)

O₂ Test Gas Kits

Rosemount Analytical's O₂ Test Gas and Service Kits have been carefully designed to provide a more convenient and fully portable means of testing, calibrating and servicing Rosemount Analytical's oxygen analyzers. These lightweight, disposable gas cylinders eliminate the need to rent gas bottles.

For more information, see PDS 106-150.A01.



Accessories for High Temperature Operation

Bypass Packages

The specially designed Rosemount Analytical Bypass Package for oxygen analyzers has proven to withstand the high temperatures in process heaters while providing the same advantages offered by the in situ sensor. Inconel or Kanthal steel tubes provide effective resistance to corrosion and the package uses no moving parts, air pumps or other components common to other sampling systems.

For more information, see PDS 106-302.A01.

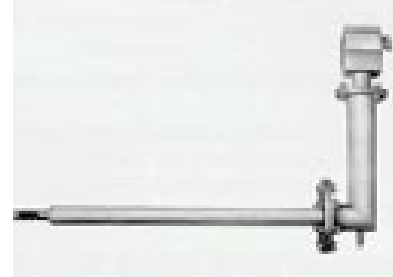

High Temperature Probe Jackets

Rosemount Analytical's patented in situ probe mounting jackets enable oxygen analyzers to operate in temperatures up to 2000°F (1093°C) in processes such as process heaters, incinerators and steam generators while providing all of the advantages offered by the in situ, zirconium oxide sensor. Ideal for high particulate applications, these jackets protect the probe from harmful flue gas condensation and use no moving parts or pumps. All components in contact with the process are constructed of high temperature tolerant stainless steel.

For more information, see PDS 106-303.A01



Oxymitter™ In Situ Flue Gas Oxygen Transmitter

The Oxymitter 4000 is the world's only in situ, zirconium oxide-based oxygen transmitter for flue gas measurement. The Oxymitter 4000 integrates an oxygen probe, field electronics and fully automatic calibrator into a single, compact package.



The contents of this publication are presented for informational purposes only, and while every effort has been made to ensure their accuracy, they are not to be construed as warranties or guarantees, express or implied, regarding the products or services described herein or their use or applicability. All sales are governed by our terms and conditions, which are available on request. We reserve the right to modify or improve the designs or specifications of our products at any time without notice.

Emerson Process Management

Rosemount Analytical Inc. Process Analytic Division

1201 North Main Street
P. O. Box 901
Orrville, OH 44667-0901 USA
T 330.682.9010
Toll Free in US and Canada 800.433.6076
F 330.684.4434
e-mail: gas.csc@EmersonProcess.com
www.processanalytic.com

