

WhisperFlo™ Trim.

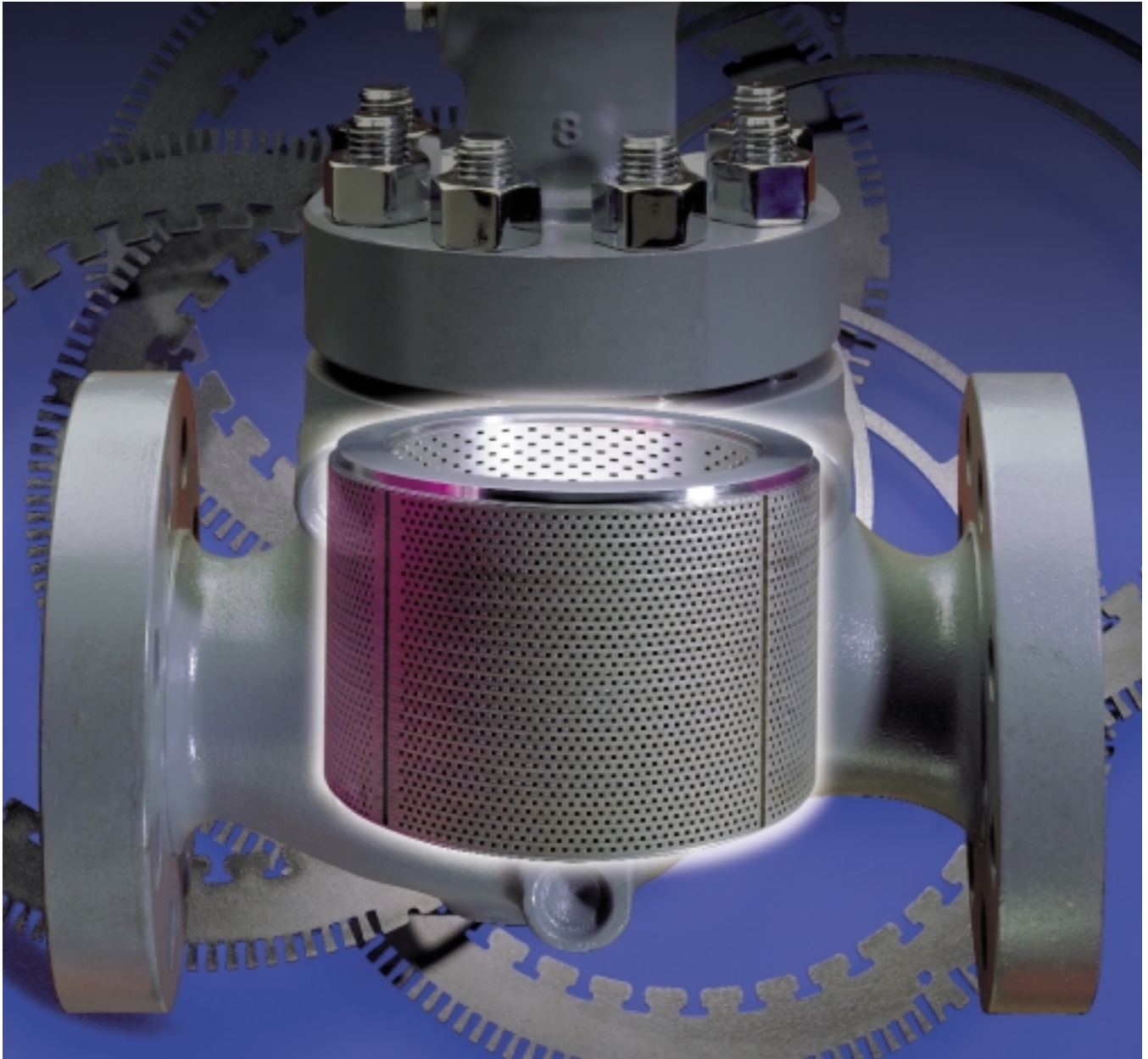

New technology that quiets control valve noise.



FISHER-ROSEMOUNT™ Managing The Process Better.™

WhisperFlo™

100% Recycled Polypropylene

100% Recycled Polypropylene

100% Recycled Polypropylene

100% Recycled Polypropylene

100% Recycled Polypropylene

100% Recycled Polypropylene

100% Recycled Polypropylene

100% Recycled Polypropylene

100% Recycled Polypropylene

100% Recycled Polypropylene

100% Recycled Polypropylene

100% Recycled Polypropylene

100% Recycled Polypropylene

100% Recycled Polypropylene

100% Recycled Polypropylene

100% Recycled Polypropylene

100% Recycled Polypropylene

100% Recycled Polypropylene

100% Recycled Polypropylene

100% Recycled Polypropylene

100% Recycled Polypropylene

100% Recycled Polypropylene

100% Recycled Polypropylene

100% Recycled Polypropylene

100% Recycled Polypropylene

100% Recycled Polypropylene

100% Recycled Polypropylene

100% Recycled Polypropylene

100% Recycled Polypropylene

100% Recycled Polypropylene

100% Recycled Polypropylene

100% Recycled Polypropylene

100% Recycled Polypropylene

100% Recycled Polypropylene

100% Recycled Polypropylene

100% Recycled Polypropylene

100% Recycled Polypropylene

100% Recycled Polypropylene

100% Recycled Polypropylene

Control Valve NOISE

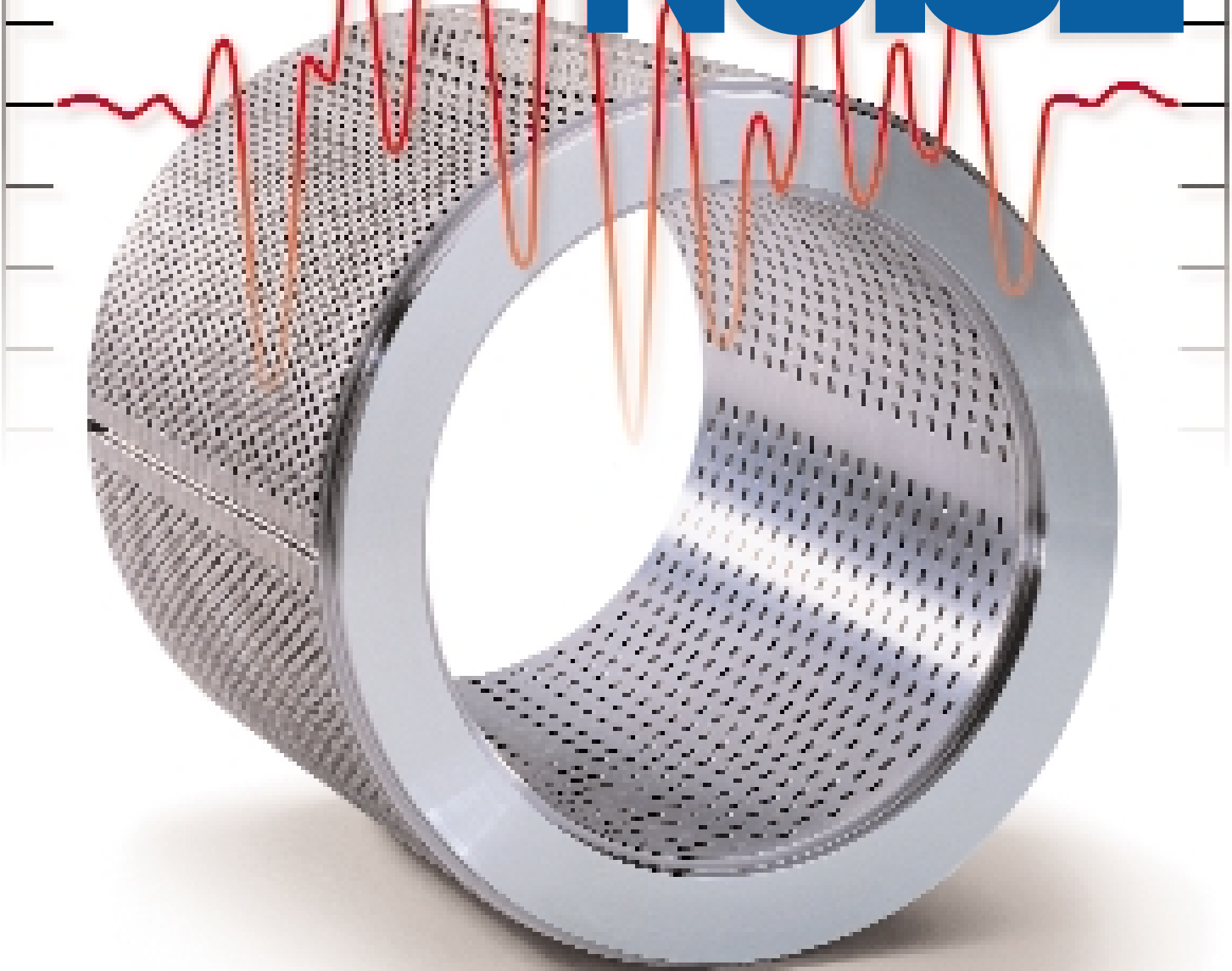

When extreme, it threatens employees' safety and well-being. It causes "bad-neighbor" situations. And potentially, it warns of valve instability and pipeline vibration that can shorten equipment life.

In answer to these valve noise problems, control valve manufacturers now offer special-design valve trims that employ various mechanisms to reduce gas, steam or vapor flow noise levels.

While these special-design noise abatement trims may prove effective, their maximum performance levels fall short of that demanded by high pressure drop and high flow rate installations.

Introducing A New Concept That Quiets Aerodynamic Flow

Introducing WhisperFlo™ trim, a new concept in multi-path, multistage, acoustic energy management that

reduces valve-caused aerodynamic noise by as much as 40 dBA. The performance capability of WhisperFlo trim surpasses conventional noise trims by 5 to 10 dBA. And importantly, WhisperFlo trim offers a noise attenuation ability that delivers predicted noise levels consistently, avoiding the costly need to recalculate and retrofit valves in order to meet performance promises.

WhisperFlo™ Trim — Combining Six Techniques For Outstanding Performance

WhisperFlo trim outperforms the noise control capabilities of conventional multi-hole trims and tortuous path designs. It does so by being the only noise abatement trim to utilize six, key noise control techniques.

Here's a detailed listing of the six operating principles which only WhisperFlo trim employs:



Note: A control valve is seldom the only noise source present within a typical industrial environment, and in fact, it may not be the major offender. There are also motors, compressors, turbines, and other mechanical or fluid handling devices which contribute to the overall noise level.

1. Unique Passage Shape

- Reduces acoustical conversion efficiency for the pressure drop ratio regime of each stage
- Reduces turbulence coming into the stage restrictions to minimize shock-associated noise
- Places turbulent shear layers away from solid boundaries to reduce dipole noise

2. Multistage Pressure Reduction

- First stage pressure drop ratio is greater than that of the second stage
- Acoustical conversion efficiency is reduced for lower pressure ratios
- Stream power is divided between stages
- First stage noise is attenuated

3. Frequency Spectrum Shift

- Reduces strain energy in piping
- Maximizes piping transmission loss to reduce radiated noise
- Reduces acoustic energy in the audible range
- Exploits the natural damping of high frequency acoustic waves

4. Exit Jet Independence

- Controls the second stage pressure ratio to avoid jet coalescence
- Adequate spacing between jets
- Jets are oriented essentially parallel to one another to avoid interaction

5. Velocity Management

- Utilizes expanding area principle to compensate for volumetric expansion of depressurizing gas

6. Complementary Body Design

- Flow up configuration
- Avoids impingement on body wall
- Adequate cavity size and shape to control secondary noise sources

Greater Capacity & Quieter, Too.

WhisperFlo trim provides significantly greater capacity than other noise trim designs in a size-for-size comparison. It does so with a smaller outside cage diameter (as shown to the right), which allows use within standard valve bodies and helps avoid costly, special body designs.

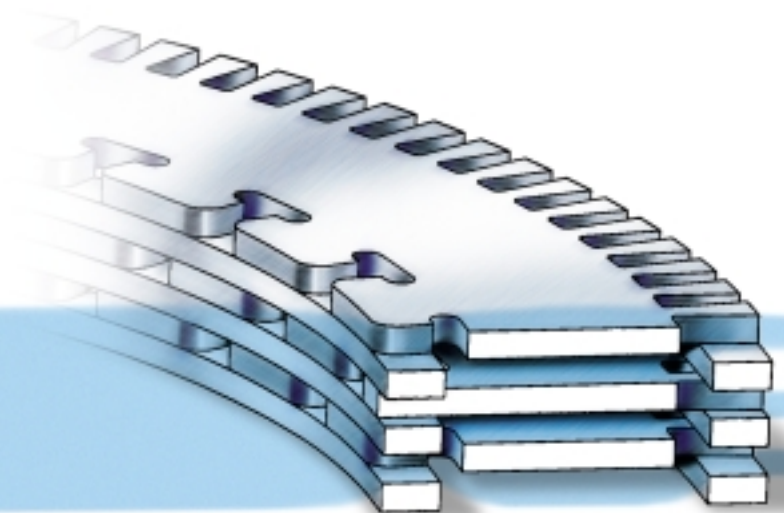
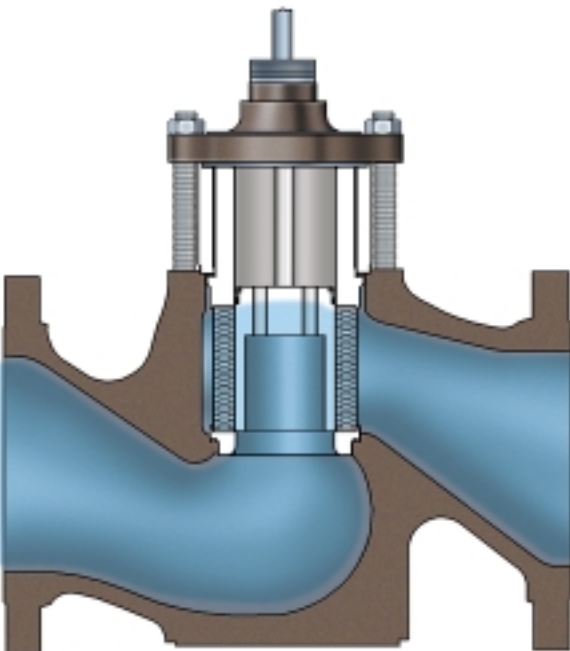
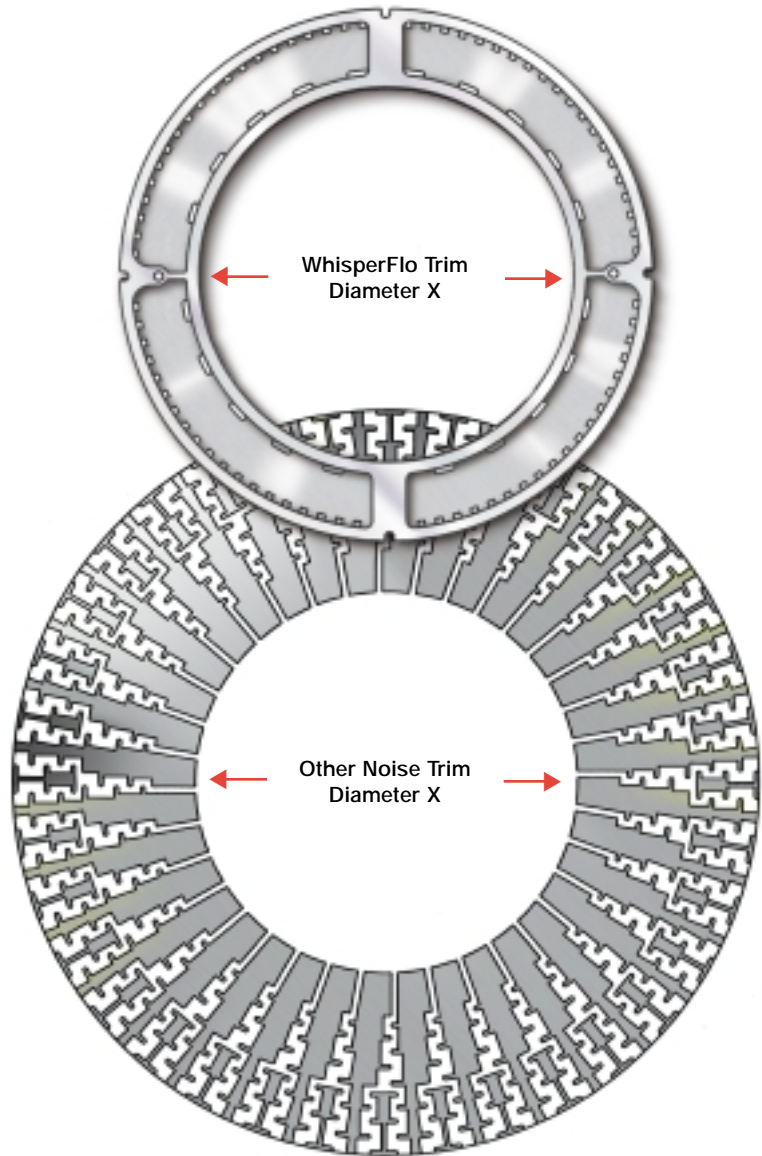

Exit Jets & Velocity Control — A Comparison That Shows The Difference

A detailed, “top-down” look (using computational fluid dynamics, or CFD) at flow through WhisperFlo trim (shown below at left) illustrates the independence of the fluid jets as they exit the cage — a WhisperFlo design advantage that prevents additional noise caused

by jet coalescence and a reduction in peak frequency.

In contrast, the exit jets of some tortuous path trim designs (shown below at right) impinge upon one another in pairs, creating an additional noise source.

Also note the locations of high velocity flow as indicated by bright yellow and orange in the color gradient. In the

tortuous path design, high velocity jets from the exit orifice can create main flow-stream turbulence, which then efficiently radiates through downstream piping as unwanted noise.

WhisperFlo trim, however, restricts high velocity flow to the first stage, and effectively contains that noise within the cage. The low velocity second stage limits main flow-stream turbulence and associated noise.

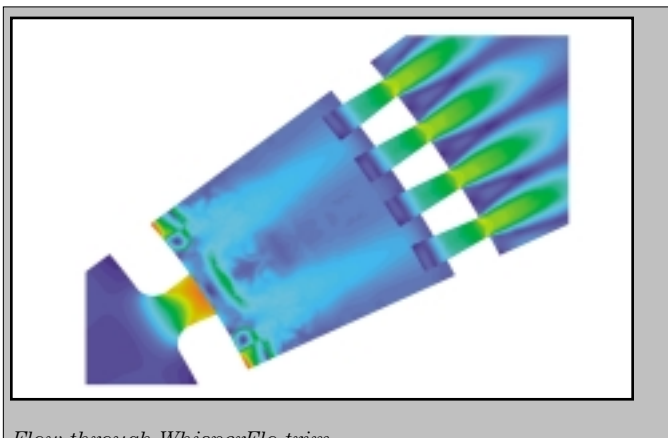

Flow through WhisperFlo trim.

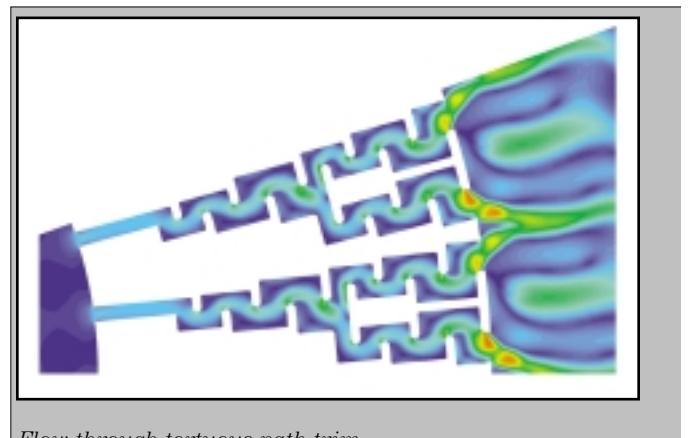

Flow through tortuous path trim.



Lasers Lead To Less Decibels

The WhisperFlo innovation in noise control also extends to innovation in manufacturing. The WhisperFlo cage consists of a stack of laser-machined discs, with the discs being permanently fused into a rigid assembly. The stack is precision-honed to exacting dimensions and ready for immediate use within standard Fisher *easy-e*® globe valve designs.

The strengths and advantages of laser-based manufacturing become readily apparent when severe application conditions demand unique disc designs. Thanks to the laser-based manufacturing technique, modifications in disc design move electronically from the engineer’s CAD program to the CNC-driven laser cutting machine. Speed of response to unique requirements is maximized, while the accuracy and economy of laser-based manufacturing is maintained.

Acoustically Speaking

Pressurized gases contain enormous amounts of stored potential energy. Pressure reducing valves convert some of this energy to other forms. Flowing fluids dissipate energy into heat via the effect of viscosity, although in turbulent flow the transformation is indirect.

The principle of *conservation of energy* dictates exactly how much power is dissipated, a conversion which is independent of the nature of the fluid passageways in the valve. However, the intermediate fluid conditions of this energy conversion process are influenced by the geometry of the fluid passageways.

The rate of this potential energy conversion is known as stream power and is expressed as $mV^2/2$. This energy is temporarily redistributed into other forms [e.g., kinetic energy of quasi-steady-state fluid stream; kinetic energy of the turbulent fluid motion; vibration of the piping; sound waves; etc.].

The fraction of the stream power that is converted into the sound power [area x $(P'')^2$] is known as *acoustical conversion efficiency* and typically varies from about 10^{-7} to 10^{-3} .

Turbulence and Noise

Turbulence is the energy source behind the generation of noise and vibration. Noise is a random collection of pressure fluctuations. Turbulence is the seemingly random motion of a fluid. But when viewed as a whole, turbulence exhibits a structure of swirling eddies ranging in size from large to small. Lighthill was the first to recognize from the Navier-Stokes equations that turbulence was a source of sound. Powell later identified eddy (vortex) formation as also creating pressure fluctuations.

The size of the eddies and the fluid velocity within them determine the predominate frequency of the pressure fluctuations via a Strouhal-type effect. A smaller eddy produces a higher frequency; WhisperFlo trim takes advantage of this phenomenon in reducing valve noise.

Turbulence from a moving stream produces *jet mixing noise* as it slows into a more stagnant fluid. For critical flow, turbulence convected through shock cells produces additional sound known as *shock-associated noise*.

Noise Categories

Acoustics experts categorize noise sources into three mathematical types: monopole, dipole and quadrupole.

Flow rate fluctuations are considered to generate monopole sound. Unsteady flow, such as turbulence interacting with a solid surface, generates dipole sound. Free-stream turbulence generates quadrupole sound.

Dipole sound power radiation is proportional to pL^2V^6/C^3 , and quadrupole sound power radiation is proportional to pL^2V^8/C^5 . (This leads to the often quoted statement that noise scales with the eighth power of velocity.) However, at subsonic speeds ($V/C < 1$) the absolute efficiency and the noise generated by a quadrupole source is less.

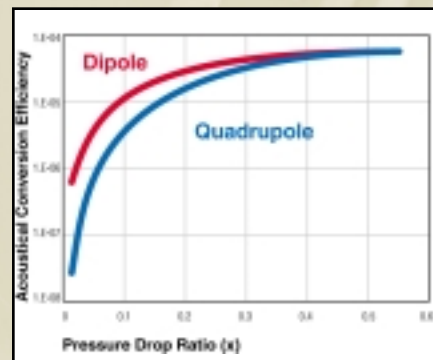

Therefore, it is important to keep flow within the quadrupole regime by keeping zones of high turbulent kinetic energy away from trim passage walls. (WhisperFlo trim also controls the location of turbulence relative to the valve body wall.) Controlling velocity alone is an impractical method to minimize noise.

Transmission Loss

Valve airborne noise is primarily radiated from downstream pipe walls which are vibrating in response to the forces induced by internal fluctuating pressure loads. The pipe most readily transmits pressure fluctuations that are distributed spatially in a manner that excites the pipe's mechanical resonant modes.

This pressure wave / to pipe wall vibration / to airborne pressure wave is a very inefficient process. External sound pressure typically is ~60dB below internal levels. Additionally, this *transmission loss* increases dramatically for frequencies above the fundamental coincident mode of the pipe wall / internal pressure waves. Consequently, high frequency noise is attenuated dramatically as illustrated in the diagram below where f_0 is the first coincidence pipe frequency.

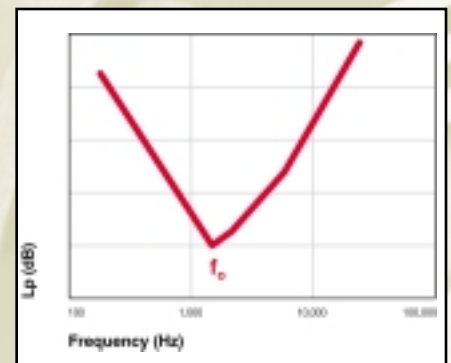

Sound Power

The radiated sound power produced by a pressure reduction process can be simply computed by:

$$W_{acoustic} = (acoustical\ conversion\ efficiency)(stream\ power) - (transmission\ loss)$$

Principles of WhisperFlo Operation

WhisperFlo technology utilizes six principles to reduce noise, vibration and pipe fatigue.

Acoustic conversion efficiency (noise generated) diminishes with a decrease in the pressure drop ratio, $\Delta P/P1$. WhisperFlo divides the pressure drop over two stages, consequently reducing the pressure drop ratio and the conversion efficiency of each stage. The stream power, likewise, is divided between stages.

WhisperFlo uses an expanding flow area design to compensate for the volumetric expansion of the depressurizing gas. The stage-to-stage flow capacity ratio is designed to optimally split the pressure reduction to minimize overall noise. Noise generated by the upstream stage is attenuated (within the WhisperFlo cage) before it reaches the downstream body cavity. Accordingly, the sound power from the unattenuated last stage is much less than that of a single-stage device.

Within the WhisperFlo cage, the high pressure ratio first stage employs a special nozzle geometry, while the low pressure ratio second stage is shaped to place turbulent shear layers away from solid boundaries. All passageways are designed to minimize turbulence coming into a normal shock.

WhisperFlo trim limits the turbulent eddy size. As a result, the predominant portion of the associated acoustic energy spectrum is not effectively absorbed by piping. Low frequency (plane wave) content that might vibrate the piping structure is reduced. High frequency vibration is not as efficiently induced in the pipewall (see below), which means pipe stress is reduced and pipe fatigue is less likely.

Pipewall attenuation is a well documented phenomenon and is an integral part of IEC aerodynamic noise calculations. In the IEC procedure, the piping transmission loss for high frequency noise is expressed by the term:

$$20 \log_{10} (f_p / f_r)$$

Ring frequency, f_r , is a function of the pipe diameter and the speed of sound (it has been used historically to express shell modes nondimensionally) and f_r approximately scales with f_o .

Peak frequency, f_p , is inversely proportional to the jet diameter, which means smaller passages generate a higher peak frequency. The result is greater transmission loss with less noise in the environment.

Also, high frequency acoustic waves are more readily damped than low frequency waves. Finally, high frequency noise is weighted less in overall dBA measurements.

An important corollary to passageway size is the independence of fluid jets as they exit the cage. If jets coalesce due to inadequate passage spacing, the frequency shift effect is defeated. Unlike turning passage designs, WhisperFlo trim also aligns the exit jets to be parallel, thereby minimizing interaction between them.

Fisher valve bodies are designed and applied so as to minimize regeneration of noise. Body cavities are adequate to avoid jet impingement onto body walls and excessive cross flow velocity into the turbulent jets emanating from the cage.

The complete valve body assembly, which has evolved from years of experience in severe service applications, also avoids associated phenomena such as acoustic cavity resonance, edge tones, hydraulic pulsation, vortex shedding and mechanical plug instabilities.

References

Control Valve Aerodynamic Noise Prediction Method, Standard 534-8-3:1995, International Electrotechnical Commission (IEC), Geneva, Switzerland

Norton, M. P., Fundamentals of Noise and Vibration Analysis for Engineers, Cambridge University Press, Cambridge, UK, 1989

An Inside Look At WhisperFlo Technology

WhisperFlo trim shifts acoustic energy to higher frequencies that are not readily absorbed by piping, thereby reducing strain energy and combating piping fatigue. Additionally, at the higher frequencies the piping radiates much less sound in the audible range.

WhisperFlo trim spaces and aligns the exit jets to be essentially parallel, thereby avoiding shock cell interaction between them (see illustrations on previous page). Direct impingement of the jets as they exit the cage on the adjacent valve body wall is avoided as well.

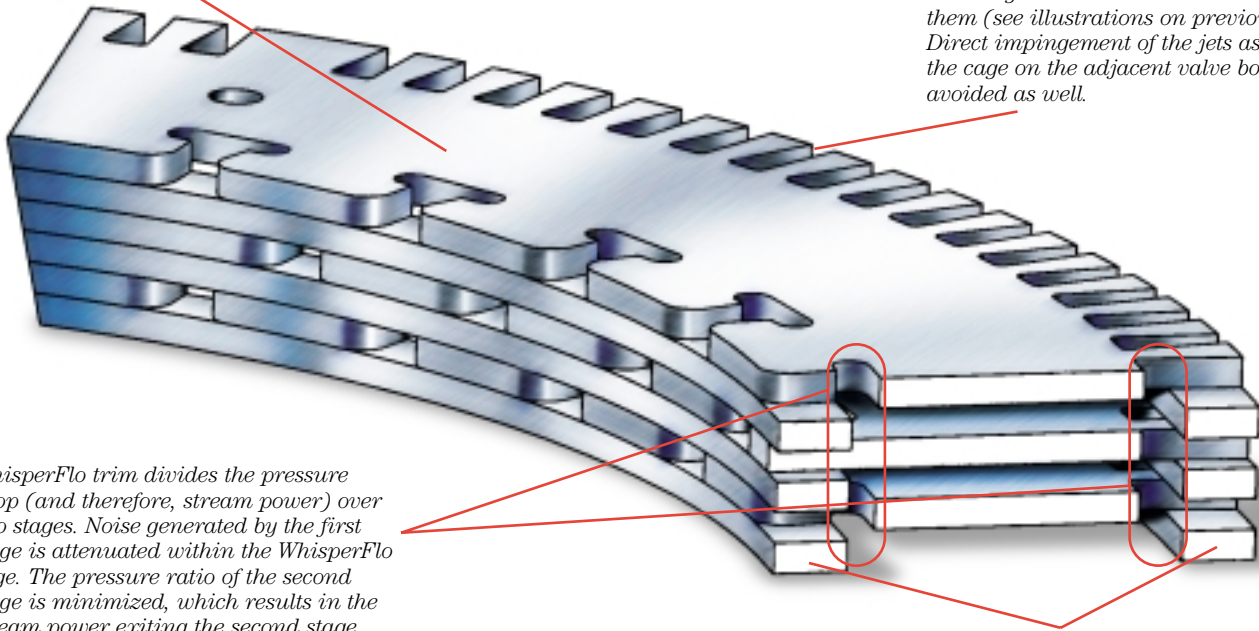

WhisperFlo trim divides the pressure drop (and therefore, stream power) over two stages. Noise generated by the first stage is attenuated within the WhisperFlo cage. The pressure ratio of the second stage is minimized, which results in the stream power exiting the second stage being significantly less than that of a single-stage device.

Unique passage shape reduces flow turbulence entering the first stage to minimize shock-associated noise. The innovative design also directs turbulent shear layers away from solid boundaries as flow exits the second stage, which further avoids dipole noise.

WhisperFlo Trim Brings New Answers To Excessive Control Valve Noise

Now you can bring aerodynamic flow applications, existing or proposed, into compliance with mandated noise limitations. Your plant or installation can be a good neighbor to adjacent, populated areas. Your employees' hearing safety can be enhanced. And you can gain improved control of those severe service, high pressure, high flow control loops.

There's more to learn about WhisperFlo trim advantages. Contact your Fisher sales office or Sales Representative for complete WhisperFlo data and for proven answers to your valve noise control problems.

The contents of this publication are presented for informational purposes only, and, while every effort has been made to ensure their accuracy, they are not to be construed as warranties or guarantees, expressed or implied, regarding the products or services described herein or their use or applicability. We reserve the right to modify or improve the designs or specifications of such products at any time without notice.

© Fisher Controls International, Inc. 1997
All Rights Reserved.

WhisperFlo, easy-e®, Fisher, Fisher-Rosemount, and Managing the Process Better are marks of the Fisher-Rosemount group of companies. All other marks are the property of their respective owners.

Fisher Controls International, Inc.

205 South Center Street
Marshalltown, Iowa 50158
Phone: (515) 754-3011
Fax: (515) 754-2830
Email: fc-valve@frmail.frco.com
Web site: www.fisher.com

