

High-Capacity Rotary Valves for General or Fibrous Slurry Service



W7419/IL

- Rotary valve efficiency with globe valve ruggedness for general gas, steam, or liquid service and for fibrous slurry applications
- DN 25 to DN 300 and 1- to 20-inch sizes
- Choice of seal types and materials--composition, flat metal, heavy-duty metal, or flow ring
- Temperatures to 427° C
- Pressures to DIN PN40 and Class 600
- ENVIRO-SEAL® packing systems to help ensure compliance with environmental emissions requirements
- FIELDVUE® digital valve controllers offer digital control and remote diagnostics. The proven line of Fisher positioners, controllers, transmitters, and switches also is available.



FISHER-ROSEMOUNT™

Product Flier PF51.3:Vee-Ball

The Vee-Ball[®] Valve Family

The Vee-Ball[®] series of rotary valves combines the features and performance you need. These features are made available through Fisher expertise in applications, valve design, and manufacturing.

These valves are suitable for throttling or on-off service. They are often used with a full 0 to 90 degree ball rotation.

The Design V150, V200, and V300 Vee-Ball[®] valves use the time-proven V-notch ball that provides high-capacity control of liquid, gas, steam, and fibrous slurries. The shearing action of the ball allows smooth, non-clogging operation, and the unrestricted, straight-through flow ensures high capacity.

Easy Installation...Design V150 and V300 integral flanges eliminate exposed flange studs, and the Design V200 features line-centering lugs to simplify alignment.

High Rangeability...Flow coefficient ratio is 300 to 1.

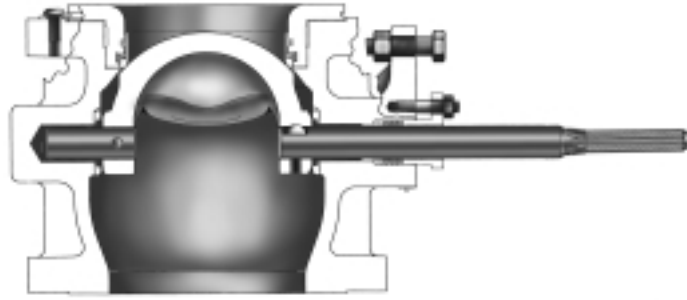

W7435/IL

Design V150 Series B Valve

Reduced Maintenance Costs...The Design V150, V200, and V300 valves have interchangeable trim parts to reduce spare parts inventory and cost and simplify maintenance procedures and training. Metal and soft seals are interchangeable within a valve body.

Easy Seal Inspection...Seals can be inspected without removing the actuator or disassembling the valve.

Protection Against Process Fluid Emissions...Optional ENVIRO-SEAL[®] packing systems provide a superior shaft seal to prevent the loss of valuable or hazardous process fluids. These live-loaded systems provide longer packing life and reliability.

Materials for Sour Service...Fisher offers materials and manufacturing procedures for compliance with NACE (National Association of Corrosion Engineers) standard MR0175.

The Vee-Ball® Valve Family (Continued)

Other Rotary Valves

The *ēplug*™ Family... The Design V500 valve uses rugged valve components and a choice of erosion-resistant trim materials for highly erosive and severe operating conditions at pressures to PN 100 (Class 600) and temperatures to 538°C.

The Design CV500 valve combines the rangeability of the cammed-segmented V-notched ball, with the inherent ruggedness found in the Design V500 heavy duty bearings, seals and body. This combination provides a balance of high capacity, erosion resistance, and pressure control for liquid and gas.

The Design BV500 valve features a specially contoured eccentric plug. The seat ring is gasketed and is retained with a screwed-in retainer. Metal-to metal seating is standard, and soft PTFE seating is optional. The Design BV500 offers an exceptional solution for many less-severe general-service applications, including low-pressure steams and fluids.

Design V250... The Design V250 valve is a heavy-duty valve often used in gas transmission lines, gas distribution, or liquid pipelines. It is available in sizes to 24 inches and Class 600 or 900 pressure-temperature ratings.

Design V260... The Design V260 valve has special energy-dissipating trim to reduce noise effects that cause pipeline vibrations. It is available in 8-through 12-inch sizes with Class 300 or 600 ratings.

Noise Attenuator Ball... Depending on service conditions, up to -10dBA acoustical attenuation and a K_C of 1.0 for liquid flow are possible with the noise attenuator ball (available with DIN DN 100 through DN 300 and ANSI 4-through 20-inch valves).

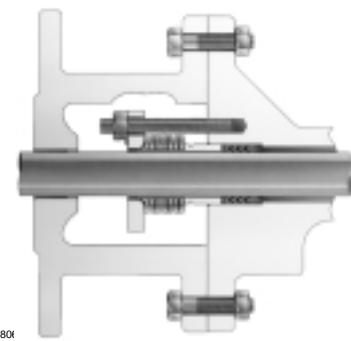

Leak-off Packing Assembly for 1- through 12-inch Valves

ENVIRO-SEAL® Packing System (Single PTFE V-Ring)

Basis Weight Control Valve... These valves are available with an electric actuator and control circuits to meet the precision control requirements of basis weight control in the paper making industry.

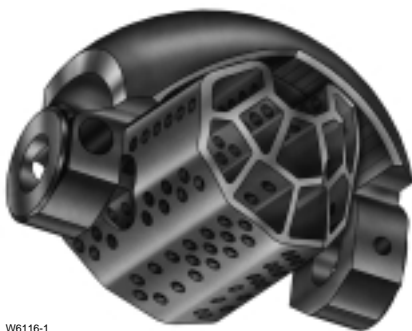

W6116-1

Noise Attenuator Ball



W5393

Basis Weight Valve and Actuator

Product Flier PF51.3:Vee-Ball

The Vee-Ball® Valve Family (Continued)



W6475-1

Type 1052 Actuator



W5978

Type 1061 Actuator

Type 1051 and 1052 Pneumatic Diaphragm Actuators...Rugged, heavy-duty spring-return actuators. These actuators are available with a variety of instrument accessories, handwheels, adjustable travel stops, and a maintenance lock-out device.

Type 1061 Pneumatic Piston Actuator...Heavy-duty piston actuator available with a variety of

instrument accessories, handwheels and piston bypass valves, and a maintenance lockout device.

Type 1078 Declutchable Handwheel Actuator...Available on Type 1051, Type 1052, and 1061 actuators.

Type 1077 Handwheel Actuator...Available for manual-only operation.

Valve Instrumentation and Accessories

FIELDVUE® Digital Valve Controller...Available mounted on Type 1051 and 1052 actuators.

Positioners and Transducers...Pneumatic positioners and electro-pneumatic positioners and transducers can be provided with these actuators.

Position Transmitters, Solenoid Valves, Volume Boosters, and Limit Switches...Also available.

MOUNTING	ACTION ⁽¹⁾	BALL ROTATION TO CLOSE	V150, V200 & V300
Right-Hand	PDTC	CCW	A
	PDTO	CCW	B
Left-Hand	PDTC	CCW	D
	PDTO	CCW	C
Left-Hand (Optional) ⁽²⁾	PDTC	CW	C
	PDTO	CW	D

1. PDTC—Push-down-to-close, and PDTO—Push-down-to-open.
 2. A left hand ball will be required for the 3- through 12-inch Series B and the 14- to 20-inch, with or without attenuator.

The Actuators are Available in any of Four Styles and Positions (Above the Pipeline as Shown Here, Below, or parallel with the Pipeline)

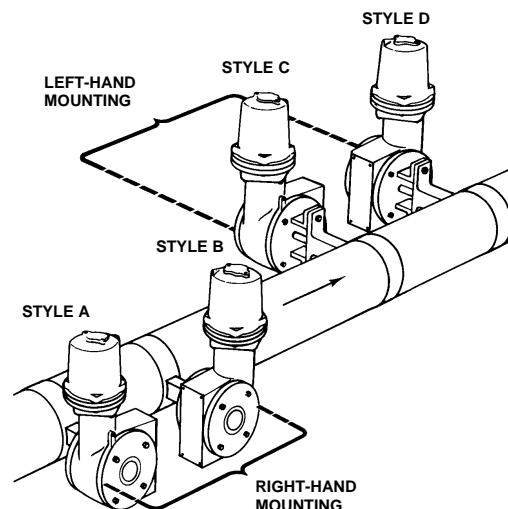

A1579-4/IL

Selecting Vee-Ball® Products

Only a few of the more commonly selected product materials, sizes, options, and accessories are covered in this flier.

Contact your nearest sales office (refer to the back cover) for assistance in selecting and sizing these products. More detailed specifications are available on request.

Selecting Valve Components

Valve Type Selection	5
Body Materials, End Connections, and Ratings	6
Valve Component Materials and Temperatures	7

Selecting an Actuator

Type 1051 and 1052 Pneumatic Diaphragm Actuators	8
Type 1061 Pneumatic Piston Actuator	9

Selecting Valve Instrumentation and Accessories

FIELDVUE® Digital Valve Controller	10
3610J Series Valve Positioners	11
Other Accessories	12

Reference Information

Maximum Inlet Pressure for CW2M Valve Bodies	14
Shutoff Pressure Drop Limits for Trim Parts	14
Flow Coefficients	15
Actuator-Valve Selection (Shutoff Pressure Drops)	16
Approximate Weights	18
Dimensions	19
Sales Offices and Sales Representatives	20

Valve Type Selection

APPLICATION			VALVE TYPE	SIZES	VALVE BODY MATERIAL	SHUTOFF CLASSIFICATION (FCI/ANSI 70-2)			
Service	Temperature	End Connection and Body Rating				Composition Ball Seal (Forward Flow)	HD (Heavy-Duty) Metal Ball Seal (Flow in Either Direction) ⁽¹⁾	Flat Metal Ball Seal (Forward Flow)	Flow Ring Construction (No Seal) (Flow in Either Direction)
General liquid, gas, or vapor service where high capacity and high reangeability (300 to 1) are required; also for fibrous slurry service	to 427°C	Integral flanges: DIN PN 10 or 16 and Class 150	V150	DN 25 - DN 300 or 1 - 20 inches	Stainless Steel: CF3M (316L), DIN 1.4408, or CG8M (317) Steel: WCC or DIN 1.0619 Hastelloy C: CW2M	Class VI	Class IV	Class IV	5% of maximum valve capacity
		Integral flanges: DIN PN 25/40 and Class 300	V300	DN 25 - DN 100 DIN or 1 - 16 inches				Class IV	
		Flangeless: Class 150, 300, 600	V200	1 - 10 inches				Class IV	

1. Limit pressure drop for the HD metal seal in the reverse direction to 6.9 bar

Product Flier PF51.3:Vee-Ball

Body Materials, End Connections, and Ratings

Design V150

Valve Body Materials	Sizes	Ratings and Raised-Face Flanges	Notes
DIN 1.0619, or DIN 1.4408	DN 25, 40, 50, 80, 100, 150, 200, 250	PN10/16	DIN materials available in DIN sizes and ratings
	DN 300	PN16	
CF3M, WCC, CG8M, or CW2M	1, 1-1/2, 2, 3, 4, 6, 8, 10, 12	Class 150	CG8M available in inch sizes and ANSI ratings only. Refer to page 14 for CW2M ratings
WCC, CG8M, or CW2M	14, 16, 20		



W6256

Micro-Notch V-Notch Ball for DN 25 or 1-Inch Valve. Use for C_v of 8.4 or Less

Design V200

Valve Body Materials	Size, Inches	Ratings and Raised-Face Flange Compatibility	Notes
WCC, CG8M, or CW2M	1, 1-1/2, 2	Class 150/300/600	Refer to page 14 for CW2M ratings
	3, 4	Class 150	
		Class 300/600	
	6, 8	Class 150/300/600	
10	Class 150		

Design V300

Valve Body Materials	Sizes	Ratings and Raised-Face Flanges	Notes
DIN 1.0619, or DIN 1.4408	DN 25, 40, 50, 80, 100	PN25/40	DIN materials available in DIN sizes and ratings
CF3M, WCC, CG8M, or CW2M	1, 1-1/2, 2, 3, 4, 6, 8, 10, 12	Class 300	Refer to page 14 for CW2M ratings
WCC, CG8M, or CW2M	14, 16		

Product Flier PF51.3:Vee-Ball

Valve Component Materials and Temperatures

BODY, SHAFT, AND BALL (TEMPERATURE IS DETERMINED BY OTHER PARTS LISTED BELOW)				
Valve Body	<ul style="list-style-type: none"> ■ CF3M (316L stainless steel), ■ DIN 1.0619 steel, ■ WCC steel, or ■ CG8M (317 stainless steel) 			
Valve Shaft	<ul style="list-style-type: none"> ■ S20910 (Nitronic 50 stainless steel) or ■ S17400 (17-4PH stainless steel) 			
V-Notch Ball	<ul style="list-style-type: none"> ■ CF3M (316L stainless steel), ■ chromium-plated CF3M, ■ CG8M (317 stainless steel), or ■ chromium-plated CG8M 			
SEAL, BEARING, AND PACKING				
SEAL MATERIAL	BEARING MATERIAL	MAXIMUM TEMPERATURE, °C		NOTES
		PTFE V-Ring Packing	Graphite Packing	
Composition (TCM plus)	<ul style="list-style-type: none"> ■ PEEK (poly-ether-ether-ketone)/PTFE, ■ R30006 (alloy 6B) or ■ silver-plated R30006 	232	232	<ul style="list-style-type: none"> ■ Minimum temperature for DIN valve bodies is -10°C ■ Minimum temperature for ANSI constructions is -29°C for steel valves and -46°C for stainless steel valves ■ Contact your sales office for ENVIRO-SEAL packing temperatures and pressures ■ Contact your sales office for pressure drops and temperatures with TCM-Ultra composition seal.
Flat metal—(spring-tempered stainless steel) (available on DN 80 through 300 [3- through 12-inch] sizes only)	PEEK/PTFE	232	260	
	<ul style="list-style-type: none"> ■ R30006, ■ silver-plated R30006, or ■ S31600L (316L stainless steel) nitride 	232	427	
HD (heavy-duty) metal (■ CF10SMnN [Nitronic 60 stainless steel] or ■ CD7MCuN [alloy 255 duplex stainless steel], or ■ R30006)	PEEK/PTFE	232	260	
	<ul style="list-style-type: none"> ■ R30006, ■ silver-plated R30006, or ■ S31600L nitride 	232	288	
Flow ring (steel or stainless to match body material)	PEEK/PTFE	232	260	
	<ul style="list-style-type: none"> ■ R30006, ■ silver-plated R30006, or ■ S31600L nitride 	232	427	
OTHER PARTS				
PART	MATERIAL	MAXIMUM TEMPERATURE, °C		
		PTFE V-Ring Packing	Graphite Packing	
Wave spring and radial seal (HD metal only)	N07750 (Inconel X750) and PTFE with N10276 (Hastelloy C)	Temperature is determined by parts listed above		
Micro-notch V-notch ball for DN 25 (1-inch) size	Chromium-plated CG8M or solid alloy 6			
	Solid VTC ceramic	93	93	
Gasket	Graphite	Temperature is determined by parts listed above		
Optional line bolting	<ul style="list-style-type: none"> ■ B7, ■ B7M, or ■ strain-hardened B8M 			

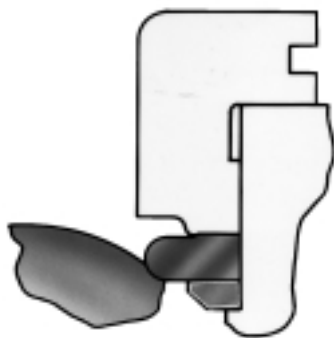

W6197-1*

Composition Seal

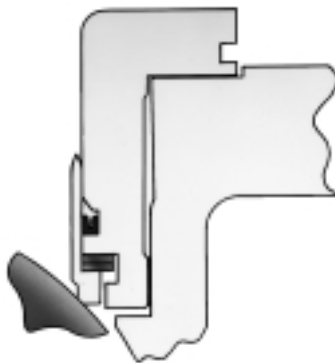

W6704-1/L

HD (Heavy-Duty) Metal Seal

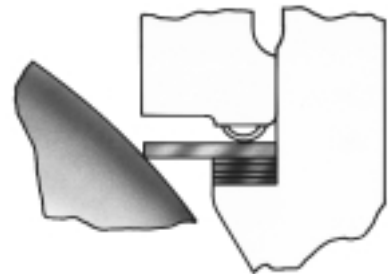

W4713-3/L

Flat Metal Seal

Product Flier PF51.3:Vee-Ball

Type 1051 and 1052 Actuators

Type 1051 and 1052 pneumatic diaphragm rotary actuators are spring-return actuators that provide reliable operation for the valves in this flier.

The Type 1051 actuator is suitable for on-off operation or for throttling operation when equipped with a valve controller or positioner. The Type 1052 actuator is suitable for on-off or throttling with or without a controller or positioner.

These actuators feature single-joint linkage with splined-and-clamped levers for minimum lost motion and high control accuracy.

The actuator-valve linkage is completely enclosed for safety, yet the packing adjustment is accessible without removing any parts.



W3813-1

Typical Type 1052 Actuator

Options... ■ Top-mounted handwheel, ■ Type 1078 declutchable handwheel actuator, ■ Adjustable up- and down-travel stops, ■ Actuator locking mechanism that keeps the actuator in a locked position during maintenance, and ■ Pipe-away vent for remote venting of the actuator housing.

Accessories... ■ Pneumatic and electro-pneumatic valve positioners, ■ FIELDVUE® digital valve controller, and ■ Limit and proximity switches.

ACTUATOR SIZE		NOMINAL OPERATING PRESSURE RANGES		MAXIMUM SIZING PRESSURE, BAR		MAXIMUM VALVE BREAKOUT TORQUE, N•m		AMBIENT TEMPERATURES, °C	MATERIALS
Type 1051	Type 1052	Bar	Psig	Type 1051	Type 1052	Type 1051	Type 1052		
---	20	■ 0 to 1.2, ■ 0 to 2.3, and ■ 0 to 2.8	■ 0 to 18, ■ 0 to 33, and ■ 0 to 40	---	3.4	---	42	Nitrile: -40 to 82 Silicone: -50 to 149	Diaphragm: Nitrile (standard) or silicone elastomers O-rings (for optional handwheel): Nitrile or EPDM Housing: Cast iron (standard) or steel Other Major Metal Parts: Aluminum, steel or cast iron
33	33	■ 0 to 1.2, ■ 0 to 2.3, ■ 0. to 2.8, and ■ 0 to 3.8	■ 0 to 18, ■ 0 to 33, ■ 0 to 40, and ■ 0 to 55	3.8		85	132		
40	40			4.5		322	371		
60	60	■ 0 to 1.2, ■ 0 to 2.3, and ■ 0 to 2.8	■ 0 to 18, ■ 0 to 33, and ■ 0 to 40	2.8		626	730		
---	70	■ 0 to 2.3, ■ 0 to 2.8, and ■ 0 to 3.8	■ 0 to 33, ■ 0 to 40, and ■ 0 to 55	---	3.8	---	1370		



W4742-1

Size 33 Actuator

Product Flier PF51.3:Vee-Ball

Type 1061 Actuators

Type 1061 pneumatic rotary actuators are double-acting piston actuators that provide reliable operation for the valves in this flier.

The Type 1061 can be used with a two-position control signal for on-off operation or with a valve controller or positioner for throttling operation.

These actuators feature single-joint linkage with splined-and-clamped levers for minimum lost motion and high control accuracy.

The actuator-valve linkage is completely enclosed for safety, yet the packing adjustment is

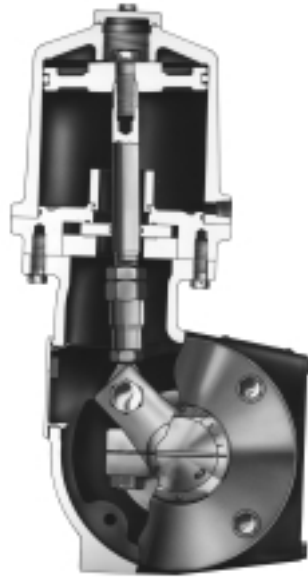

accessible without removing any parts.

Options... ■ Type 1078 declutchable handwheel actuator with cylinder bypass valve,
 ■ Actuator locking mechanism that keeps the actuator in a locked position during maintenance, and
 ■ Pipe-away vent for remote venting of the actuator housing.

Accessories... ■ Pneumatic and electro-pneumatic valve positioners and ■ Limit and proximity switches.

ACTUATOR SIZE	CYLINDER OPERATING PRESSURE, BAR		MAXIMUM VALVE BREAKOUT TORQUE, N•m	AMBIENT TEMPERATURES, °C	MATERIALS
	Minimum Recommended	Maximum Allowable			
30	Without positioner: 1.4 With positioner: 0.35 bar above actuator requirement	6.9	282	-34 to 82 (to -50 with optional materials)	Cylinder and flange: Aluminium Piston: aluminum or nylon-coated aluminum O-rings: Nitrile Mounting yoke bushing: PTFE and steel Sliding seal: Brass Other parts: Iron, aluminum, and stainless steel
40		10.3	847		
60		6.9	1130		
68		5.9	1540		
80		10.3	5080		
100		10.3	6290		

Product Flier PF51.3:Vee-Ball

Type DVC5020 Digital Valve Controller

FIELDVUE digital valve controllers are communicating, microprocessor-based controllers that convert a current signal to a pressure signal to operate the actuator. The controller gives easy access to actuator-valve information that is critical to process operation.

ValveLink

Software...ValveLink™ software allows easy access to the information available from the valve. The software provides diagnostic information such as dynamic error band and step response on easy-to-interpret screens.



W7419/IL

Type DVC5020 Controller on a Valve and Actuator

Access to diagnostics is through a Model 275 HART communicator or a personal computer using Windows™ software.

Options...Process PID, autocalibrate (AC) for automatic calibration and ease of installation, advanced diagnostics (AD), and pressure gauges.

CE Mark...The FIELDVUE controller has the CE Mark to EMC Directive (electromagnetic compatibility).

FIELDVUE DVC5020 Valve Controller Physical Specifications

SUPPLY PRESSURE, BAR		OUTPUT SIGNAL	STEADY-STATE AIR CONSUMPTION, Nm ³ /h	TEMPERATURE LIMITS	WEIGHT	HOUSING
Minimum and Recommended	Maximum					
As needed by actuator	6.9	Up to 95% of supply pressure	Less than 0.3 at 1.4 bar supply pressure	-40 to 80°C	2.7 kg	IP65 per IEC 60529

FIELDVUE DVC5020 Digital Communication Input Signal

HART® 1200 Baud Frequency Shift Keyed				
Analog Input Signal	Minimum Voltage	Minimum Control Current	Minimum Current without Microprocessor Restart	Maximum Current
■ 4 to 20, ■ 4 to 12 or ■ 12 to 20 mA dc (user adjustable)	12 Vdc for HART communication; 11.5 Vdc for analog control	4.0 mA	3.5 mA	100 mA
FOUNDATION™ fieldbus 31,250 Baud				
Input Signal		Minimum Voltage		Nominal Current
All-digital programmable function blocks		9 Vdc		20 mA

FIELDVUE DVC5020 Digital Controller Certifications

INTRINSIC SAFETY		INTRINSIC SAFETY OR NON-INCENDIVE	FLAMEPROOF		DIVISION 2		EXPLOSION-PROOF
LCIE	CSA ⁽¹⁾ or FM ⁽¹⁾		SAA	CENELEC	SSA	CSA	
EEx ia IIC T5 (T _{amb} 80°C)	Class I, Division 1, Groups ⁽¹⁾ A, B, C, D T5 (T _{amb} 80°C)	Ex n IIC T5, T6 Ex ia IIC T4, T5, T6	EEx d IIB + H ₂ T5 (T _{amb} 80°C)	EEx d IIB + H ₂ T6 (T _{amb} 80°C)	Class I Division 2, Groups A, B, C, D Class II, Division 2 Groups E, F, G	Class I Division 2, Groups A, B, C, D Class II, Division 2 Groups F, G	Class I Division 1 Groups B, C, D Class II, Division 1, Groups E, F, G

1. Contact your nearest sales office for the appropriate FM entity ratings and CSA parametric ratings for each group.

Product Flier PF51.3:Vee-Ball

3610J Series Valve Positioners

The 3610J Series pneumatic and 3620J Series electro-pneumatic valve positioners can be used with Type 1051, 1052, or 1061 actuators for accurate valve positioning in throttling applications.

The positioners provide accurate, fast response and can withstand the vibrations in most plants.



W4920-1*

The positioners are easily reversible for direct or reverse action without additional parts.

The 3610J and 3620J positioners are single acting for Type 1051 and 1052 actuators, and the 3610JP and 3620JP positioners are double acting for Type 1061 actuators.

Options... ■ Supply pressure gauge, ■ Tire valves for clip-on gauges, and ■ Integrally mounted bypass valve for single-acting actuators

3610J and 3620J Positioner Specifications

Type	Input Signal		Supply Pressure	Operative Temperature	Weight	Connections
3610J and 3610JP	■ 0.2 to 1.0 or ■ 0.4 to 2.0 bar	■ 3 to 15 or ■ 6 to 30 psig	0.3 bar above the actuator requirement up to 10.3 bar maximum	-40 to 80°C	2.5 kg	Pressure and Vent Connections: 1/4-inch NPT Type 3620J and JP Conduit: 1/2 NPT
3620J and 3620JP	4 to 20 mA constant current with 30 Vdc maximum compliance voltage; equivalent circuit is 120 ohms shunted by three 5.6 V zener diodes		0.3 bar above the actuator requirement up to 10.3 bar maximum	-40 to 80°C	3.6 kg	

3610J and 3620J Series Capacities and Housing

Type	Supply Pressure, Bar	Supply Air Demand, Nm ³ /h	Air Consumption, Nm ³ /h	Housing (Types 3620J and 3620JP)
3610J and 3620J	1.4	13	Type 3610J: 0.40 at 1.4 bar supply Type 3620J: 0.49 at 1.4 bar supply	IP 54 per IEC 60529 classification (weatherproof), NEMA 3; vent should be on the side or bottom for weatherproof applications
	2.4	17		
3610JP and 3620JP	5.2	37	Type 3610JP: 0.64 at 6.9 bar supply Type 3620JP: 0.93 at 6.9 bar supply	
	6.9	46		

Typical 3622 Electro-Pneumatic Converter Certifications (The Converter is Part of 3620J Positioners)

INTRINSIC SAFETY		INTRINSIC SAFETY OR NON-INCENDIVE	FLAMEPROOF		DIVISION 2		EXPLOSION-PROOF
PTB	CSA ⁽¹⁾ or FM ⁽¹⁾	SAA	LCIE	SSA	CSA	FM	CSA or FM
EEx ia IIC T6 (T _{amb} 50°C) IK=120mA T5 (T _{amb} 50°C) IK=150mA T4 (T _{amb} 80°C) IK=150mA	Class I, Division 1, Groups ⁽¹⁾ A, B, C, D T5	Ex ia IIC T4 Ex n IIC T4	EEx d IIC T6 (T _{amb} 40°C)	Ex d IIB T6	Class I Division 2, Groups A, B, C, D Class II, Division 2 Groups E, F, G	Class I Division 2, Groups A, B, C, D Class II, Division 2 Groups F, G	Class I Division 1 Groups A, B, C, D Class II, Division 1, Groups E, F, G

1. Contact your nearest sales office for the appropriate FM entity ratings and CSA parametric ratings for each group.

Product Flier PF51.3:Vee-Ball

Other Accessories

Type 3065 Limit Switch Box

The limit switch box can be installed on the actuator to hold proximity or microswitches, which can turn on an alarm or display device when a pre-set limit is reached. Additional microswitches are available.

The device has separate cams for open and closed positions, and adjustment of one cam does not affect the other.

W6682B



Certifications...CE Mark to EMC directive ■ EN 50081 and ■ EN 50082

Self-Adjusting...Complicated adjustments are not required.

Standardized Installation...Covered by IEC 60534-6 (NAMUR). The box can be supplied with a mounting kit.

Type 3065 Limit Switch Specifications

HOUSING	
Makrolon plastic or aluminum housing	
-40 to 80°C ambient temperature for housing	
DIN 40 050-IP65 housing enclosure	
SWITCHES	
Type EI - S inductive proximity switch, slot shaped EEx ia IIC T6	Type IE - Z inductive proximity switch, cylindrical shaped EEx ia IIC T6
P & F Model SJ3.5 N or SN	P & F Model NJ2-11-N-G or SN-G
-25 to 75°C (N) -40 to 100°C(SN) DIN 40 050--IP 67	-25 to 100°C (N-G) -25 to 100°C (SN-G) DIN 40 050--IP 68
Rating voltage is 8 V ($R_f \sim 1k$) Operating voltage is 5 - 25 V	
Type EM Microswitch	Type EM-Ex microswitch EEx d IIC T6
Burgess V4NT7AR1	Bartec 07-2501-6-30/63
-40 to 80°C DIN 40 050--IP54	-25 to 70°C DIN 40 050--IP54
Alternate current switching capacity at 125 or 250 V:	Alternate current switching capacity at 125 or 250 V:
5.0 A resistive load 0.5 A light-bulb load 5.0 A inductive load	7.0 A resistive load 0.5 A light-bulb load 5.0 A inductive load
Direct current switching capacity: 5 A at 30 v or 0.25 A at 250 V resistive load 2 A (opening) and 1.5 A (closing) at 30 V light-bulb load 0.1 A (opening) and 0.2 A (closing) at 250 V light-bulb load 3 A at 30 V or 0.03 A at 250 V inductive load	Direct current switching capacity: 10 A at 15 v or 0.25 A at 250 V resistive load 2 A at 15 V or 0.2 A 250 V light-bulb load 10 A at 15 V or 0.03 A at 250 V inductive load

Other Accessories (Continued)

Type 67CFR

Filter-Regulator...The Type 67CFR provides constantly controlled supply pressure to actuator accessories system. This regulator features an internal filter and limited-capacity internal relief, allowing partial reduction of downstream pressure.



W7412

Type 67CFR Filter-Regulator with Optional Gauge



W4727

Type 2625 Volume Booster

Type 67CFR Filter-Regulator Specifications

OUTLET PRESSURE SETTINGS		MAXIMUM INLET PRESSURE (BODY RATING), BAR	MAXIMUM DIAPHRAGM PRESSURE, BAR	TEMPERATURE CAPABILITIES	CONNECTIONS	MAXIMUM FLOW COEFFICIENT, C _v	WEIGHT, kg
Bar	Psig						
0 to 1.2 0 to 2.1 0 to 3.4 0 to 5.5	0 to 20 0 to 35 0 to 60 0 to 100	17.2	3.4 over outlet setting	Nitrile (NBR) parts: -40 to 82°C Fluoroelastomer (FKM) parts: -18 to 149°C	Inlet and Outlet: 1/4-inch NPT female Vent: ■ Untapped hole or ■ 1/4-inch NPT female	0.36	0.5

Type 646 or 846 Electro-Pneumatic Transducers...

These transducers convert a standard 4 to 20 mA dc signal to a proportional pneumatic signal. Certifications are ■ CE Mark to EMC directive (electromagnetic compatibility);
■ Contact your nearest sales office

for intrinsic safe and flameproof ratings.

Type 2625 Volume Booster...

The volume booster can be used in conjunction with a positioner to increase actuator stroking speed.

Others... ■ High-pressure supply pressure regulators, ■ proximity switches, ■ microswitches, and ■ solenoid valves.

Contact your nearest sales office for more information.

Product Flier PF51.3:Vee-Ball

Maximum Inlet Pressure for CW2M (Hastelloy C) Valve Bodies

TEMPERATURE, °C	MAXIMUM INLET PRESSURE, BAR			NOTE
	150	300	600	
-46 to 38	20.0	51.7	103	CW2M is not listed in ASME B16.34. The designations 150, 300, and 600 indicate relative pressure-retaining capabilities and are not ANSI pressure-temperature rating classes.
93	17.9	51.7	103	
149	15.9	50.3	100	
204	13.8	48.6	97.2	
232	12.8	47.2	94.5	

Shutoff Pressure Drop Limits for Trim Parts



WARNING

Pressure drops in the following table consider only the trim parts (ball, shafts, bearings, and seals).

The pressure drops shown might be higher than the DIN or ANSI pressure-temperature rating of the valve body or mating flanges. Do not exceed the DIN or ANSI pressure-temperature rating of the valve or mating flanges, as exceeding the pressure-temperature rating may cause personal injury or equipment damage.

In the following tables, the lower temperature limit is -10°C for DIN valves, -29°C for ANSI steel valves, and -46°C for ANSI stainless steel valves.

Also refer to the actuator sizing pages to select an actuator size.

Pressure Drop in Bar (For HD Metal Seal, Pressure Drops are for Forward Flow Only. For Reverse HD Seal Flow, Limit Pressure Drop to 6.9 Bar)

BEARING MATERIAL	BALL SEAL	TEMPERATURE, C	VALVE SIZE												
			1	1-1/2	2	3	4	6	8	10	12	14	16	20	
			DN 25	DN 40	DN 50	DN 80	DN 100	DN 150	DN 200	DN 250	DN 300	---	---	---	
PEEK/PTFE	TCM Plus	-46 to 38	51.0	51.0	51.0	51.0	51.0	51.0	51.0	51.0	40.2	37.6	31.0	23.8	31.0
		93	37.9	37.9	37.9	37.9	37.9	37.9	37.9	37.9	37.9	37.6	31.0	23.8	31.0
		149	24.1	24.1	24.1	24.1	24.1	24.1	24.1	24.1	24.1	24.1	24.1	23.8	24.1
		204	10.3	10.3	10.3	10.3	10.3	10.3	10.3	10.3	10.3	10.3	10.3	10.3	10.3
		232	3.45	3.45	3.45	3.45	3.45	3.45	3.45	3.45	3.45	3.45	3.45	3.45	3.45
	HD Metal	-46 to 288	51.0	51.0	51.0	51.0	51.0	51.0	51.0	40.9	38.1	40.3	26.5	40.3	
	Flat Metal	-29 to 260	---	---	---	20.7	20.7	20.7	20.7	10.3	10.3	---	---	---	
Flow Ring	---	99.3	99.3	99.3	99.3	72.4	75.2	73.8	40.5	37.7	40.5	35.0	44.7		
R30006	HD Metal	-46 to 288	51.0	50.0	25.7	17.5	11.0	10.9	11.2	6.14	5.72	6.14	7.52	6.83	
	Flat Metal	-29 to 260	---	---	---	17.0	10.1	10.7	10.6	5.86	5.52	---	---	---	
	Flow Ring	---	74.5	49.6	26.8	18.8	10.9	11.2	11.1	6.07	5.65	6.07	7.31	6.69	
R30006 Silver Plated	HD Metal	-46 to 288	51.0	51.0	51.0	35.0	22.1	21.8	22.5	12.3	11.4	12.3	13.2	13.7	
	Flat Metal	-29 to 260	---	---	---	20.7	20.1	20.7	20.7	10.3	10.3	---	---	---	
	Flow Ring	---	99.3	99.3	53.5	37.6	21.8	22.5	22.2	12.1	11.3	12.1	14.6	13.4	
S44004	HD Metal	-46 to 288	51.0	51.0	51.0	---	---	---	---	---	---	---	20.5	13.2	14.0
	Flat Metal	-29 to 260	---	---	---	---	---	---	---	---	---	---	---	---	
	Flow Ring	---	99.3	99.3	88.9	---	---	---	---	---	---	---	20.2	20.1	22.3
S31600L Nitride	HD Metal	-46 to 288	---	---	---	51.0	36.7	36.3	37.4	20.5	19.1	---	---	---	
	Flat Metal	-29 to 260	---	---	---	20.7	20.7	20.7	20.7	10.3	10.3	---	---	---	
	Flow Ring	---	---	---	---	62.7	36.3	37.4	37.0	20.2	18.8	---	---	---	

Product Flier PF51.3:Vee-Ball

Flow Coefficients

Design V150, V200, and V300 (Forward Flow)

VALVE SIZE		VALVE ROTATION, DEGREES (LINE SIZE EQUALS VALVE SIZE)															
		10	30	60	90	10	30	60	90	10	30	60	90	10	30	60	90
		C _v				K _v				F _L				X _T			
Composition Seals, Flat Metal Seals (DN 50 - DN 300 & 3 - 12 inches only), and Flow Ring Construction																	
DN 25 ⁽¹⁾	1 ⁽¹⁾	.0098	2.53	12.4	34.6	.0085	2.19	10.7	29.9	.93	.90	.84	.69	.392	.571	.507	.275
DN 40 ⁽¹⁾	1-1/2 ⁽¹⁾	.014	6.15	27.8	76.0	.012	5.32	24.0	65.7	.87	.86	.82	.73	.492	.548	.516	.328
DN 50 ⁽¹⁾	2 ⁽¹⁾	.028	9.60	46.1	123	.024	8.30	39.9	106	.94	.90	.83	.75	.386	.585	.559	.366
DN 80	3	.746	27.7	120	321	.645	24.0	104	278	.91	.88	.80	.74	.664	.628	.501	.302
DN 100	4	3.56	47.2	195	596	3.08	40.8	169	516	.88	.90	.80	.62	.697	.792	.518	.221
DN 150	6	5.34	82.1	340	1100	4.62	71.0	294	952	.93	.91	.80	.58	.574	.770	.518	.200
DN 200	8	6.99	122	518	1820	6.05	106	448	1570	.89	.90	.82	.54	.526	.735	.537	.176
DN 250	10	43.5	252	1000	3000	37.6	218	865	2600	.85	.88	.80	.56	.219	.735	.473	.189
DN 300	12	44.2	390	1530	3980	38.2	337	1320	3440	.81	.83	.78	.63	.366	.632	.490	.245
---	14	60.0	541	1670	5610	51.9	468	1450	4850	.89	.79	.80	.37	.999	.605	.593	.198
---	16	70.0	692	2380	8270	60.6	599	2060	7150	.89	.79	.80	.37	.273	.566	.452	.133
---	20	110	993	3070	10,300	95.2	859	2660	8910	.89	.79	.80	.73	.999	.605	.593	.198
HD (Heavy-Duty) Metal Seats																	
		C _v				F _L				X _T							
DN 25	1 ⁽¹⁾	.0503	2.53	11.3	33.1	.0435	2.19	9.77	28.6	.95	.94	.88	.68	.829	.687	.553	.243
DN 40	1-1/2 ⁽¹⁾	.0180	4.20	23.2	70.8	.0156	3.63	20.1	61.2	.91	.94	.87	.70	.591	.683	.561	.265
DN 50	2 ⁽¹⁾	.020	6.75	40.4	122	.017	5.84	34.9	106	.89	.91	.87	.72	.749	.589	.558	.314
DN 80	3	.169	24.1	112	338	.146	20.8	96.9	292	.96	.91	.82	.73	.710	.597	.563	.278
DN 100	4	.108	34.2	158	539	.093	29.6	137	466	.89	.94	.82	.64	.941	.718	.605	.233
DN 150	6	.996	56.9	290	1070	.862	49.2	251	925	.94	.95	.84	.58	.578	.788	.544	.185
DN 200	8	1.41	94.7	481	1750	1.22	81.9	416	1510	.96	.89	.80	.51	.348	.693	.508	.158
DN 250	10	7.28	199	897	2950	6.30	172	776	2550	.97	.90	.79	.54	.107	.664	.494	.174
DN 300	12	7.48	291	1300	4010	6.47	252	1120	3470	.97	.92	.82	.60	.800	.710	.508	.228
---	14	56.0	502	1550	5200	48.4	434	1340	4500	.89	.79	.80	.37	.999	.605	.593	.198
---	16	30.0	600	2040	7840	26.0	519	1770	6780	.89	.79	.80	.37	.965	.593	.533	.135
---	20	105	942	2910	9770	90.8	815	2520	8450	.89	.79	.80	.37	.999	.605	.593	.198
Micro-Notch V-Notch Ball (Metal Ball with Composition or HD (Heavy-Duty) Metal Seal)																	
		C _v				F _L				X _T							
DN 25	1	.0143	.360	1.43	5.23	.0124	.311	1.24	4.52	.95	.93	.90	.88	.551	.660	.620	.578
Micro-Notch V-Notch Ball (Ceramic Ball with HD (Heavy-Duty) Metal Seal)																	
		C _v				F _L				X _T							
DN 25	1	.0180	.415	1.78	3.64	.0156	.389	1.54	3.15	.90	.94	.90	.92	.581	.693	.612	6.12

1. The coefficient listed for 10 degrees was measured at 12 degrees rotation.

Line-to-Valve Size Ratios Greater than 1-to-1 and Coefficients for Valves with a Noise Attenuator Ball

Contact your nearest sales office for information on determining the F_P, the piping geometry factor (for greater line-to-valve ratios) and for information on the noise attenuator ball.

Product Flier PF51.3:Vee-Ball

Actuator-Valve Selection (Shutoff Pressure Drops)

Note

The intent of the actuator-valve selection tables is to present an actuator size that will control a relatively high valve pressure drop with a standard actuator operating pressure. It is not implied that the selection shown is best for your application.

For pressure drops lower than those shown, a lower actuator pressure or smaller actuator might be satisfactory.

For pressure drops higher than those shown, a higher operating pressure or larger actuator will be required.

Contact your sales office for other sizes and operating pressures.

With rotary valves, the highest pressure drop occurs when the valve is shut off. When the valve is open, pressure drop is normally much lower. However, pressure drop capabilities of a rotary valve also are lower when the valve is open. The allowable flowing pressure drop across a valve depends on the valve construction, valve position, the type of flowing fluid (liquid or gas), and on the vapor pressure and critical pressure ratio of liquids.

Only allowable shutoff pressure drops are shown here. To determine the allowable flowing pressure drop, provide your sales office with your application pressures, temperatures, and pressure drops.

Do not exceed any other limits presented in this flier. Following is a brief reminder of some of those limits:

Maximum Shutoff Pressure Drop...

Do not exceed any of the pressure drops in this table or in the Maximum Allowable Shutoff Pressure Drops section.

Maximum Inlet Pressure and Temperature...

Do not exceed the maximum pressure rating of the valve. Refer to the Body Materials, End Connections, and Ratings section.

Materials Temperature Limits...

Refer to the Valve Materials and Temperatures section, the actuator specifications tables, and the accessories specifications tables. Some of the critical limits are repeated here.

Temperature Capabilities Summary

Process Temperature	Minimum	DIN: -10°C ANSI: -29°C for steel valves and -46°C for stainless steel valves			
	Maximum	Packing	Seal	Bearing	---
		PTFE	Any	Any	232°C
		Graphite	Composite	Any	232°C
			Flat metal and flow ring	PEEK	260°C
				Metal	427°C
			HD	PEEK	260°C
Metal	288°C				
Ceramic micro-notch ball				93°C	
Ambient Temperature	Type 1051 and 1052 actuators	-40 to 82°C with nitrile elastomers and -50°C to 149°C with silicone			
	Type 1061 actuator	-34 to 82°C (to -50°C with optional materials)			
	Type DVC5020 controller and 3610J Series positioners	-40 to 80°C			

Product Flier PF51.3:Vee-Ball

Actuator-Valve Selection (Forward Flow)

Type 1052 Actuator

BEARING AND SEAL MATERIAL	VALVE SIZE		AIR TO OPEN (PUSH-DOWN-TO-OPEN)				AIR TO CLOSE (PUSH-DOWN-TO-CLOSE)			
			Actuator Size	Pressure Drop, Bar	Pressure to Actuator		Actuator Size	Pressure Drop, Bar	Pressure to Actuator	
					Bar	Psig			Bar	Psig
PEEK Bearings with Composition Seal	DN 25	1	20	51.0	0 to 1.2	0 to 18	20	51.0	0 to 1.2	0 to 18
	DN 40	1-1/2	20	51.0	0 to 1.2	0 to 18	33	51.0	0 to 1.2	0 to 18
	DN 50	2	33	51.0	0 to 1.2	0 to 18	33	51.0	0 to 1.2	0 to 18
	DN 80	3	33	51.0	0 to 1.2	0 to 18	40	51.0	0 to 1.2	0 to 18
	DN 100	4	40	51.0	0 to 1.2	0 to 18	40	51.1	0 to 1.2	0 to 18
	DN 150	6	60	51.0	0 to 1.2	0 to 18	60	43.3	0 to 1.2	0 to 18
	DN 200	8	60	51.0	0 to 1.2	0 to 18	60	51.0	0 to 2.3	0 to 33
	DN 250	10	70	51.0	0 to 2.3	0 to 33	60	51.0	0 to 2.3	0 to 33
DN 300	12	70	46.9	0 to 2.3	0 to 33	70	51.0	0 to 2.3	0 to 33	
PEEK Bearings with HD (Heavy-Duty) Metal Seal (Lubricated Service)	DN 50	2	20	51.0	0 to 1.2	0 to 18	33	51.0	0 to 1.2	0 to 18
	DN 80	3	33	51.0	0 to 1.2	0 to 18	40	51.0	0 to 1.2	0 to 18
	DN 100	4	40	51.0	0 to 1.2	0 to 18	40	51.0	0 to 1.2	0 to 18
	DN 150	6	60	51.0	0 to 1.2	0 to 18	60	51.0	0 to 1.2	0 to 18
	DN 200	8	70	51.0	0 to 2.3	0 to 33	60	51.0	0 to 2.3	0 to 33
	DN 250	10	70	51.0	0 to 2.3	0 to 33	70	15.3	0 to 2.3	0 to 33
DN 300	12	70	35.2	0 to 2.3	0 to 33	70	26.5	0 to 2.3	0 to 33	
PEEK Bearings with HD (Heavy-Duty) Metal Seal (Non-Lubricated Service)	DN 50	2	20	51.0	0 to 1.2	0 to 18	33	51.0	0 to 1.2	0 to 18
	DN 80	3	40	51.0	0 to 1.2	0 to 18	40	51.0	0 to 1.2	0 to 18
	DN 100	4	40	51.0	0 to 1.2	0 to 18	60	51.0	0 to 1.2	0 to 18
	DN 150	6	60	51.0	0 to 1.2	0 to 18	60	51.0	0 to 1.2	0 to 18
	DN 200	8	70	51.0	0 to 2.3	0 to 33	70	51.0	0 to 2.3	0 to 33
	DN 250	10	70	51.0	0 to 2.3	0 to 33	70	43.6	0 to 2.3	0 to 33
DN 300	12	70	26.6	0 to 2.3	0 to 33	70	18.1	0 to 2.3	0 to 33	
PEEK Bearings with Flat Metal Seal	DN 25	1	20	20.7	0 to 1.2	0 to 18	33	20.7	0 to 1.2	0 to 18
	DN 40	1-1/2	33	20.7	0 to 1.2	0 to 18	33	20.7	0 to 1.2	0 to 18
	DN 50	2	33	20.7	0 to 1.2	0 to 18	33	20.7	0 to 1.2	0 to 18
	DN 80	3	40	20.7	0 to 1.2	0 to 18	40	20.7	0 to 1.2	0 to 18
	DN 100	4	60	20.7	0 to 1.2	0 to 18	60	20.7	0 to 1.2	0 to 18
	DN 150	6	60	20.7	0 to 1.2	0 to 18	60	20.7	0 to 2.3	0 to 33
	DN 200	8	60	20.7	0 to 2.3	0 to 33	60	20.7	0 to 2.3	0 to 33
	DN 250	10	60	10.3	0 to 2.3	0 to 33	60	10.3	0 to 2.3	0 to 33
DN 300	12	70	9.3	0 to 2.3	0 to 33	70	7.5	0 to 2.3	0 to 33	
PEEK Bearings with Flow Ring Construction	DN 25, 40	1, 1-1/2	20	51.0	0 to 1.2	0 to 18	20	50.1	0 to 1.2	0 to 18
	DN 50	2	20	51.0	0 to 1.2	0 to 18	33	50.1	0 to 1.2	0 to 18
	DN 80	3	33	51.0	0 to 1.2	0 to 18	33	50.1	0 to 1.2	0 to 18
	DN 100	4	40	51.0	0 to 1.2	0 to 18	40	50.1	0 to 1.2	0 to 18
	DN 150	6	60	51.0	0 to 1.2	0 to 18	60	50.1	0 to 1.2	0 to 18
	DN 200	8	60	51.0	0 to 1.2	0 to 18	60	50.1	0 to 2.3	0 to 33
	DN 250	10	70	51.0	0 to 2.3	0 to 33	60	50.1	0 to 2.3	0 to 33
	DN 300	12	70	51.0	0 to 2.3	0 to 33	70	50.1	0 to 2.3	0 to 33

Product Flier PF51.3:Vee-Ball

Actuator-Valve Selection (Forward Flow—Continued))

Type 1061 Actuator

VALVE SIZE		TYPE 1061 SIZE	PRESSURE DROP, BAR	PRESSURE TO ACTUATOR		TYPE 1061 SIZE	PRESSURE DROP, BAR	PRESSURE TO ACTUATOR		TYPE 1061 SIZE	PRESSURE DROP, BAR	PRESSURE TO ACTUATOR	
				Bar	Psig			Bar	Psig			Bar	Psig
		Composition Seal				HD (Heavy-Duty) Metal Seal (Lubricated Service)				HD (Heavy-Duty) Metal Seal (Non-Lubricated Service)			
DN 25	1	30	51.0	4.1	60	30	51.0	4.1	60	30	51.0	4.1	60
DN 40	1-1/2	30	51.0	4.1	60	30	51.0	4.1	60	30	51.0	4.1	60
DN 50 - 100	2 - 4	30	51.0	4.1	60	30	51.0	4.1	60	30	51.0	4.1	60
DN 150	6	30	51.0	5.5	80	30	51.0	4.1	60	30	51.0	4.1	60
DN 200	8	30	47.9	5.5	80	40	51.0	4.1	60	40	48.3	4.1	60
DN 250	10	40	51.0	4.1	60	40	40.5	5.5	80	60	51.0	4.1	60
DN 300	12	60	51.0	4.1	60	68	51.0	4.1	60	68	51.0	4.1	60
		Flat Metal Seal				Flow Ring Construction				---			
DN 25, 40	1, 1-1/2	30	20.7	4.1	60	30	51.0	4.1	60	---			
DN 50 - 150	2 - 6	30	20.7	4.1	60	30	51.0	4.1	60	---			
DN 200	8	40	20.7	4.1	60	40	51.0	4.1	60	---			
DN 250	10	40	10.3	4.1	60	40	51.0	4.1	60	---			
DN 300	12	60	9.9	4.1	60	40	43.4	4.1	60	---			

Approximate Weights

Weights are in kilograms and are for valve and actuator combined. Not all possible valve and actuator size combinations are shown.

Designs V150, V200, and V300 Valves with Actuator

VALVE SIZE		TYPE 1051 ACTUATOR				TYPE 1052 ACTUATOR				TYPE 1061 ACTUATOR			
		Size	V150	V200	V300	Size	V150	V200	V300	Size	V150	V200	V300
DN 25	1	33 40	26 49	25 48	28 51	20 30	20 27	19 26	22 29	30	28	27	30
DN 40	1-1/2	33 40	28 51	26 49	32 55	20 30	22 29	20 27	26 33	30	30	28	34
DN 50	2	33 40	29 52	30 53	37 60	20 30	23 30	24 31	31 38	30	31	32	39
DN 80	3	33 40 60	33 56 102	35 58 104	43 71 117	33 40	34 58	36 60	49 73	30	35	37	50
DN 100	4	40 60	69 115	65 111	80 126	40 60	71 118	67 114	82 129	30	48	44	59
DN 150	6	40 60	85 131	79 125	103 149	60	134	128	152	30	64	58	82
DN 200	8	60	161	151	192	60 70	164 195	154 185	195 226	30 40	94 101	84 91	125 132
DN 250	10	60	196	203	289	60 70	199 230	206 237	292 323	40 60	136 146	143 153	229 239
DN 300	12	60	246	---	382	70	280	---	416	40 60 68	186 196 213	---	322 332
---	14	60	336	---	463	60	339	---	466	68	303	---	349 430
---	16	---	---	---	---	---	---	---	---	80 100	455 468	---	632 645
---	20	---	---	---	---	---	---	---	---	80 100	646 659	---	---

Product Flier PF51.3:Vee-Ball

Dimensions

For Design V150 and V200 valves through DN 300 (12 inches), the standard face-to-face dimension is IEC 534-3-2 (ISA S75.04). The optional face-to-face dimension for these sizes is ISA B16.10 Short. The face-to-face dimension for DN 350 and DN 400 (14 and 16 inches) is ISA B16.10 Short. The face-to-face dimension for DN 500 (20 inches) is 508 mm. Face-to-face dimensions for DIN versions of these valves are the same as for the ANSI versions and might not conform to any standard other than those mentioned here.

Dimension A and X (mm)

VALVE SIZE		A					X
DIN	ANSI, Inches	Standard		Optional		V300 (IEC 534-3-2 & ISA S75.04)	
		V150	V200	V150	V200 (Class 150 Only)		
DN 25	1	102		127		102	232
DN 40	1-1/2	114		165		114	258
DN 50	2	124		178		124	264
DN 80	3	165		203		165	290
DN 100	4	194		229		194	301
DN 150	6	229		267		229	324
DN 200	8	243		292		243	380
DN 250	10	297	297	330	330	297	408
DN 300	12	338	---	356	---	338	451
---	14	381	---	---	---	381	629
---	16	406	---	---	---	406	601
---	20	508	---	---	---	---	692

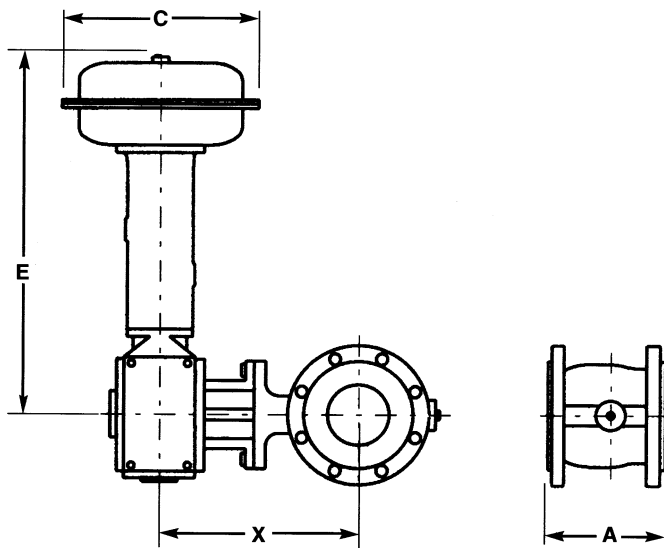

A6901/IL

Dimensions C and E (mm)

Actuator Type	Actuator Size	C	E
1051	33	289	338
	40	333	505
	60	473	749
1052	20	251	256
	33	289	338
	40	333	607
	60	473	876
1061	70	536	849
	30	171	378
	40	206	425
	60	267	406
	68	324	483
	80	324	714
	100	381	714

Product Flier PF51.3:Vee-Ball

For Further Information, Contact...

AUSTRIA

Fisher-Rosemount
Industrie - Zentrum No
Sud Straße 2a, obj M29
A- 2351 Wr. Neudorf
Telephone +43.2236.607
Fax +43.2236.60744

BELGIUM

Fisher-Rosemount
De Kleetlaan 4
B-1831 Diegem
Telephone +32.2.716.77.11
Fax +32.2.725.83.00

BULGARIA

Process Control
Tzarichina Str.1
BG- 1505 Sofia
Telephone +359.2.70.35.49
Fax +359.2.75.91.43

CIS

Fisher-Rosemount
Malaya Trubetskaya
Street 8 - 11th floor
CIS-119881 Moscow
Telephone +7.095.232.69.68
Fax +7.095.232.69.70

CROATIA

Fisher-Rosemount
Berry Commerce
Zagorska 27
10000 Zagreb
Telephone +385.1.305.071.
Fax +385.1.33.59.25

CZECH Rep

Fisher-Rosemount
Volsinách 75
Cz- 100 97 Praha 10
Telephone +420.2.810.026.66
Fax +420.2.810.026.70

DENMARK

Fisher-Rosemount
Hejrevang 11
DK-3450 Allerød
Telephone +45.48.17.03.33
Fax +45.48.17.02.44

FINLAND

Oy Valmet-Rosemount
Sinimaentie 10B
FIN - 02630 Espoo
Telephone +358.9.523.500
Fax +358.9.523.997

FRANCE and MIDDLE EAST

Fisher-Rosemount
2, place Gustave Eiffel
Silic 247
F- 94568 Rungis
Telephone +33.01.49.79.73.00
Fax +33.01.49.79.73.99

GERMANY

Fisher-Rosemount
Mannheimerstr. 63
D-67071 Ludwigshafen
Telephone +49.0621.6811.0
Fax +49.0621.6811.359

GREECE

T.C.B.
44, Pentelis str.
GR-17564 Faliro-Athens
Telephone +30.1.80.33.652
Fax +30.1.80.33.819

HUNGARY

Fisher-Rosemount
Ersébet Királyné útja 1/c
Hu- 1146 Budapest
Telephone +36.1.462.40.00
Fax +36.1.343.01.73

ITALY

Fisher-Rosemount
Via dell' Artigianato 8/12
I-20053 Muggiò (Mi)
Telephone +39.39.2.278.0590
Fax +39.39.2.270.2302

NETHERLANDS

Fisher-Rosemount
Patrijsweg 140
NL-2289 EZ Rijswijk
Telephone +31.70.413.66.66
Fax +31.70.390.68.15

NORWAY

SAAS SA
Postboks 6500 Etterstad
Grenseveien 95
N- 0606 OSLO
Telephone +47.23.19.30.00
Fax +47.23.19.30.96

POLAND

Fisher-Rosemount
Al. Wilanowska 272
PL- 02665 Warszawa
Telephone +48.22.85.73.766
Fax +48.22.85.73.856

PORTUGAL

Fisher-Rosemount
Rua Alfredo da Silva 8
P-2720 Alfragide
Telephone +351.01.471.28.850
Fax +351.01.472.88.55

ROMANIA

Fisher-Rosemount Romania
Calea Floreasca No. 91-11
BL. F1, Tronson 5. AP.44
Sector 1
RO-71401 Bucharest
Telephone +40.1.230.41.49
Fax +40.1.230.05.01

SLOVAK Rep

Fisher-Rosemount
Hanulova 5/b
SR- 84101 Bratislava
Telephone +421.07.787.811
Fax +421.07.787.245

SLOVENIA

MIR
Strmeckijeva 16
SI-8270 Krsko
Telephone +386.608.231.470
Fax +386.608.231.471.

SPAIN

Fisher-Rosemount
Ctra Fuencarral-Alcobendas
Km 12.2; Edificio Auge 1
E-28049 Madrid
Telephone +34.1.358.91.41
Fax +34.1.358.91.45
: fr.spain@frco.com

SWEDEN

PEAB
Ilanda Gård 120
S - 65350 Karlstad
Telephone +46.54.53.07.50
Fax +46.54.53.18.51

SWITZERLAND

Fisher-Rosemount
Blegistr. 21
CH-6341 Baar
Telephone +41.41.768.61.11
Fax +41.41.761.87.40

TURKEY

Fisher-Rosemount Proses Kontrol
Kisikli Caddesi
Basaran Ap. N° 3 Kat2
81130 Altunizade
TR- Üsküdar Istanbul
Telephone +90.216.492.40.42-46
Fax +90.216.492.40.47

UKRAINE

Fisher-Rosemount
Tereschenkovskaya St. 13,
Rm. 58
252004 Kiev
Telephone +38.44.246.46.56
Fax +38.44.246.46.58

UNITED KINGDOM

Fisher-Rosemount
Horsfield Way
Bredbury
Stockport SK6 2SU
UK
Telephone +44.161.406.8826
Fax +44.161.406.8827

WEB site: www.fisher.com

These products may be covered by one or more of the following patents: (4,519,579; 4,129,625; 5,131,666; 5,056,757; 5,230,498; and 5,299,812) or under pending patents. Cam-Vee-Ball, ENVIRO-SEAL, FIELDVUE, FloVue, Fisher, Fisher-Rosemount, Managing The Process Better, ValveLink and Vee-Ball are marks owned by Fisher Controls International, Inc. or Fisher-Rosemount Systems, Inc. HART is a mark owned by the HART Communications Foundation. All other marks are the property of their respective owners.

© Fisher Controls International, Inc. 1997, 2001; All Rights Reserved
The contents of this publication are presented for informational purposes only, and while every effort has been made to ensure their accuracy, they are not to be construed as warranties or guarantees, express or implied, regarding the products or services described herein or their use or applicability. We reserve the right to modify or improve the designs or specifications of such products at any time without notice.

For information, contact Fisher:
Marshalltown, Iowa 50158 USA
Cernay 68700 France
Sao Paulo 05424 Brazil
Singapore 128461



FISHER-ROSEMOUNT™